

2-corner, 2-height Electronic System
Aftermarket Light-Duty Applications

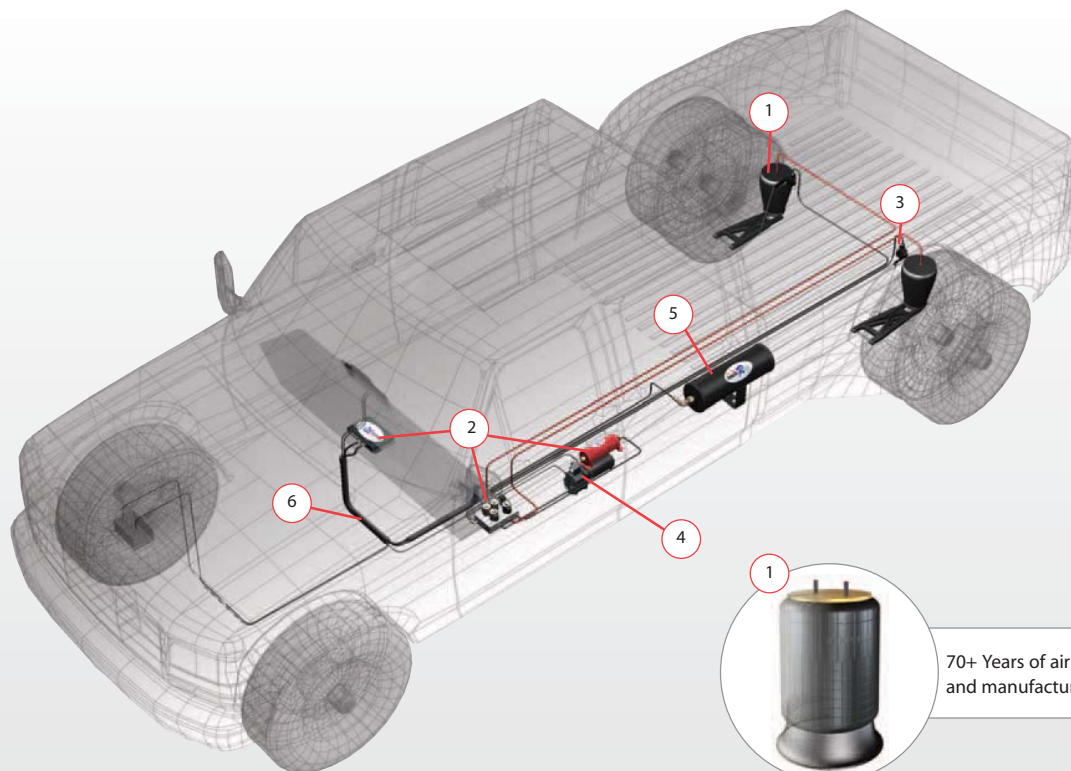

Smart.



70+ Years of air spring engineering and manufacturing expertise.

2 Air Supply Unit



- Environmentally sealed ECU
- Solenoid controlled valve block
- Desiccant air dryer
- All units certified against dust and up to 1m water immersion

3 Control Sensors

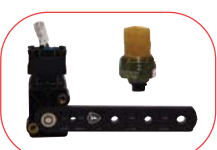

- Electronic Height Sensor
- Certified against dust and prolonged immersion in water
- Tested 5,000,000+ cycles
- Pressure Sensor

4 Air Compressor

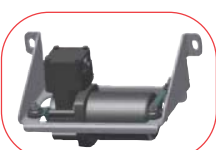

- Electronically controlled for extended life
- Module design for easy assembly
- Diaphragm isolation mounts to reduce vibration and noise

5 Air Tank

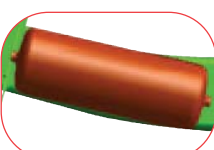

- 3 Gallon capacity
- Stored energy allows faster response times

6 Wire Harness



- Ergonomic controls and easy to read labeling
- Certified against dust and water immersion
- Plug-and-play installation

7 Diagnostics



- Downloadable diagnostic and calibration tool
- Easy to use, step by step instructions

EUROPE
Driverite Ltd.
www.driveriteltd.com
 email: sales@driveriteltd.com
 ph: +353 1 4507833 fax: +353 1 4509739

USA
Firestone Industrial Products Company
www.fsip.com/intelliride
 ph: 800.888.0650 (for North America)

Key Features and Benefits

It's Smart

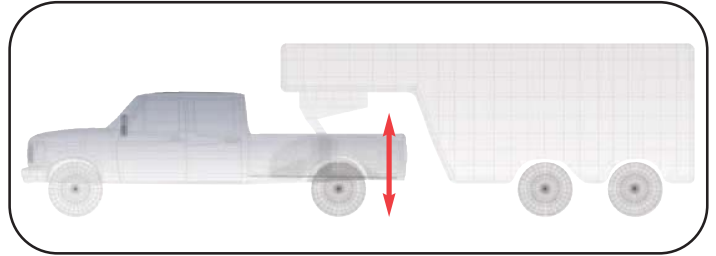

- Set custom heights dependent upon your specific application
- Automatic load leveling sustains vehicle height and stance regardless of load.
- Get on the road faster! Hitching your trailer has never been easier.

Easy Installation



- Preassembled component bracketry for fewer parts
- Simple snap-in wire harness, valve block, and pneumatic connections
- Well labeled controls and detailed instructions

Superior Quality and Durability



- Desiccant air dryer eliminates moisture and it's damaging effects
- Engineered by the world's largest air spring manufacturer, **Firestone**

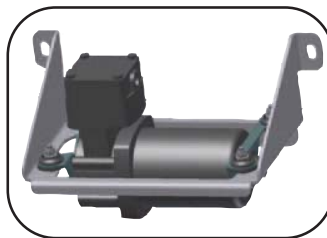

- Precision kneeling conserves system pressure and extends compressor life
- Continuously monitored system increases safety and reduces air consumption

www.driveriteltd.com

