



## INSTALLATION INSTRUCTIONS

Read installation instructions completely before installing your Coil-Rite Kit

### PREPARE THE VEHICLE

Remove the negative battery cable. With the vehicle on a solid level surface, chock the front wheels. Raise the vehicle by the rear axle and remove the rear wheels. Lower the vehicle's frame on to jack stands rated for your vehicle's weight, making sure the suspension is fully extended. *Do NOT use wood or concrete blocks to support the weight of the vehicle.*

### STEP 1 - PREPARE THE AIR SPRING

Cut a section of air line tubing 3 inches in length and insert into the push-to-connect air inlet on the air spring (a "saw" cut with a sharp knife is preferred). Exhaust the air from the air spring by rolling it up toward the air inlet. After the air is exhausted, install the plug into the tubing in the air spring *see Figure "A"*.

### STEP 2 - INSTALL THE AIR SPRING

Insert the top of the flattened air spring into the coil spring through the lowest opening between the turns with the push-to-connect fitting at the top *see Figure "B"*

### STEP 3 - ADJUST THE AIR SPRING

Push the air spring up into the coil spring by hand or with a blunt tool, such as a 1/2" socket extension. Do NOT use anything with sharp edges or corners as this may damage the air spring.

When the air spring is completely within the coil spring, remove the plug and three inch tubing section by pushing the collar on the fitting towards the air spring and pulling out the tubing. Allow the air spring to return to its normal shape.

#### WARNING:

Do not inflate this assembly when it is unrestricted. The assembly must be restricted by a coil spring. Do not ever inflate beyond recommended operating pressure for your specific vehicle. Improper use or over inflation may cause property damage or severe personal injury.

**FIRESTONE INDUSTRIAL PRODUCTS**  
**CARMEL, INDIANA, USA**

### PARTS LIST

DESCRIPTION	QTY.
AIR SPRING	2
PLUG	2
18' AIR LINE	1
NYLON TIE	6
PUSH-TO-CONNECT INFLATION VALVE	2
5/16" FLAT WASHER	4

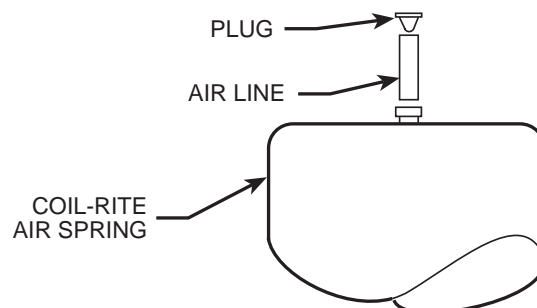

Figure "A"

### RECOMMENDED OPERATING PRESSURE

SUV 5 - 35 p.s.i.

Firestone Industrial Products  
12650 Hamilton Crossing Blvd. - Carmel, IN 46032  
1-800-247-4337 - [www.ride-rite.com](http://www.ride-rite.com)

# AIR LINE INSTALLATION

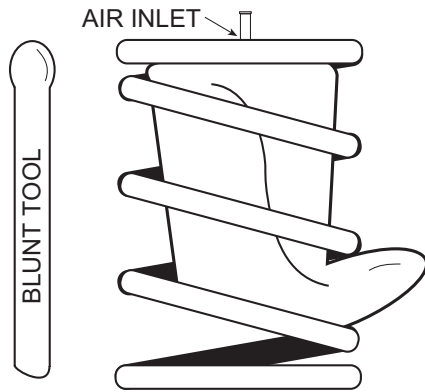

Figure "B"

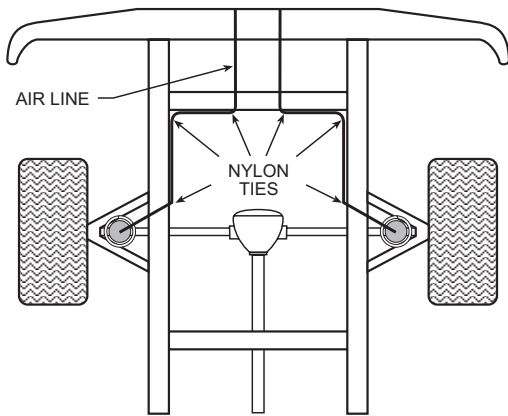

Figure "C"

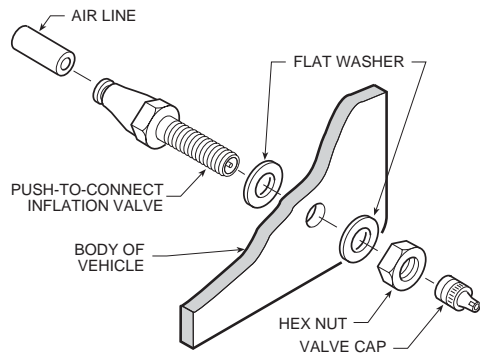

Figure "D"

## STEP 4 - ROUTE THE AIR LINE

Cut the remaining air line tubing into two equal lengths (a square "saw" cut with a sharp knife is preferred). *Note: The inflation valve will be installed in step 6.*

Insert the air line tubing into the push-to-connect fitting on the air spring as far as possible. Route the tubing from the air spring to the desired location of the inflation valve, making sure to avoid direct heat from the exhaust pipe and away from sharp edges. Secure the tubing to the vehicle with the provided nylon ties *see Figure "C"*.

## STEP 5 - INSTALL THE AIR LINE AND INFLATION VALVE

Select a location on the vehicle for the air inflation valves. This location can be on the bumper or the body of the vehicle, as long as it is in a protected area so the valve will not be damaged, but maintain accessibility for the air chuck *see Figure "C"*. Drill a 5/16" hole and install the air inflation valve using two 5/16" flat washers per valve as supports *see Figure "D"*.

*Follow steps 1-5 for the opposite-side air spring.*

## STEP 7 - INFLATE AND TEST

Inflate the air springs to recommended operating pressure (see page 1 for recommended operating pressures). With a soap and water solution, check for air leaks around the fittings and valve core. We recommend inflating and deflating in 5 p.s.i. increments to find the ideal riding condition for your vehicle.

## STEP 8 - COMPLETION

This now completes the installation. Install the wheels and torque the lug nuts to the manufacturers specifications. Raise the vehicle and remove the jack stands and lower the vehicle to the ground. Reattach the negative battery cable.

**PLEASE TAKE ALL NECESSARY SAFETY PRECAUTIONS WHEN INSTALLING YOUR COIL-RITE KIT.**

**NOTE: CHECK AIR PRESSURE ON A MONTHLY BASIS.**