



www.riderite.com

Read installation instructions completely before installing your Coil-Rite Kit

STEP 1 AIR SPRING PREPARATION

With the vehicle on a solid level surface chock the wheels and raise the vehicle using a jack rated for your vehicle weight to lift the wheels off the surface. Remove the wheels. Lower the vehicle frame onto jack stands rated for your vehicles weight making sure the suspension is fully extended. (Do NOT use wood or concrete blocks to support the weight of the vehicle.)

If necessary, additional clearance between the coil turns may be obtained by removing the shock absorbers from the lower shock mounts and lowering the suspension an additional one to two inches. (CAUTION: Do not put strain or tension on the flexible brake line.)

Cut a section of air line tubing approximately three inches in length. (Cut the tubing as squarely as possible.) Install the tubing into the push-to-connect air inlet on the air spring. Exhaust the air from the air spring by rolling it up toward the air inlet. After all the air is removed from the air spring install the hose plug into the end of the hose as shown in *Figure "A"*.

STEP 2 PLACING SUPPORTS

Insert the support between the air spring and the coil spring seat as shown in *Figure "B"*.

STEP 3 INSTALLING THE AIR SPRING

Insert the top of the flattened air spring into the coil spring through the lowest opening with the push-to-connect air inlet at the top as shown in *Figure "A"*.

Push the air spring up into the coil spring by hand or with a blunt tool, such as a spoon shaped tire iron. Do NOT use anything with sharp edges or corners as this may damage the air spring.

When the air spring is completely within the coil spring, remove the plug and three inch tubing section by pushing the collar on the fitting towards the air spring and pulling on the tubing to remove. Allow the air spring to return to its normal shape.

PARTS LIST

| DESCRIPTION | QTY. |
|---------------------------------|------|
| AIR SPRINGS | 2 |
| UPPER SUPPORTS | 2 |
| PLUG | 2 |
| 18' AIR LINE | 1 |
| NYLON TIE | 6 |
| PUSH-TO-CONNECT INFLATION VALVE | 2 |
| 5/16" FLAT WASHER | 4 |

WARNING

Do not inflate this assembly when it is unrestricted. The assembly must be restricted by a coil spring. Do not ever inflate beyond recommended operating pressures for your specific vehicle. Improper use or over inflation may cause property damage or severe personal injury.

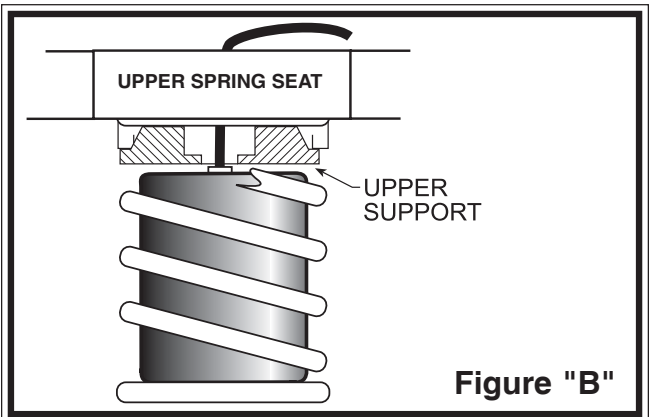
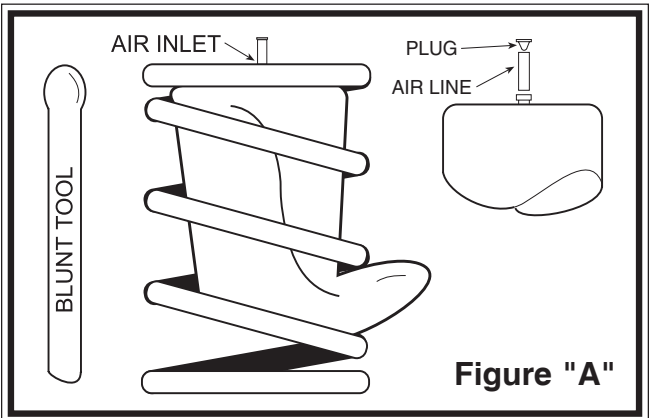

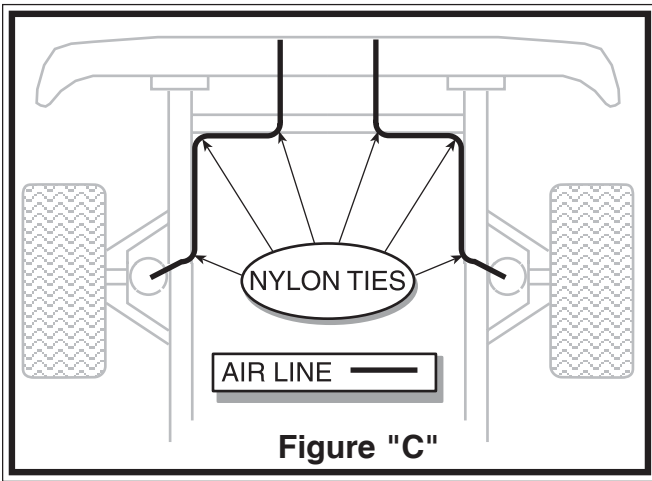

STEP 4 REATTACH THE SHOCK ABSORBER

Attach shock absorbers if removed earlier in the installation.

STEP 5 ROUTE THE AIR LINE

Cut the remaining air line tubing into two equal lengths (cut the tubing as squarely as possible). Select a location for the inflation valves in a protected area, such as the bumper or trunk floor (Note: The inflation valve will be installed in step 7).

Insert the air line tubing into the push-to-connect fitting on the air spring as far as possible. Route the tubing from the air spring to the inflation valve, making sure to avoid direct heat from the engine, exhaust pipe and away from sharp edges. Secure with nylon ties provided in your kit.

STEP 6 INSTALL THE AIR LINE AND INFLATION VALVE

Select a location on the vehicle for the air inflation valves. The location can be located on the bumper or the body of the vehicle, as long as it is in a protected location so the valve will not be damaged, but maintain accessibility for the air chuck *see Figure "C"*. Drill a 5/16" hole and install the air inflation valve using two 5/16" flat washers per valve as supports *see Figure "D"*.

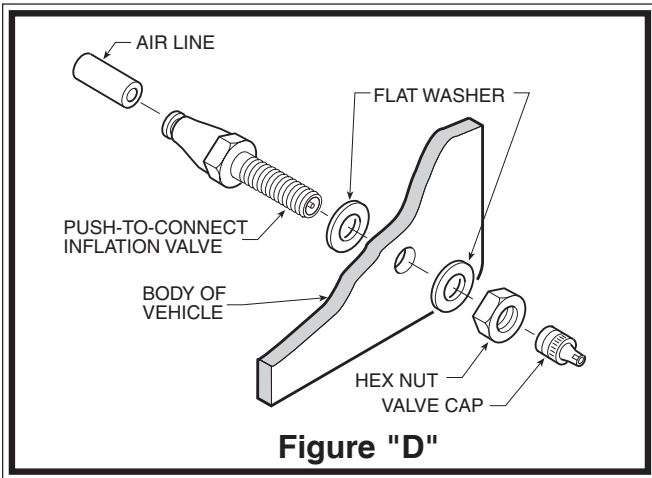

Follow steps 1-6 for the other air spring.

STEP 7 INFLATE AND TEST

Inflate the air springs to recommended operating pressure (see page 1 for operating pressures). With a soap and water solution, check for air leaks around the fittings and valve core. We recommend inflating and deflating in 5 p.s.i. increments to find the ideal riding condition for your vehicle.

STEP 8 COMPLETION

This now completes the installation. Install the wheels and torque the lug nuts to the manufacturers specifications. Raise the vehicle and remove the jack stands and lower the vehicle back onto the ground.

NOTE:
MIN PRESSURE (UNLOADED):
5 PSI

MAX PRESSURE (LOADED):
35 PSI

NOTE: Check air pressure on a monthly basis.