



Unit 626 Kilshane Avenue, North West Business Park, Ballycoolin, Dublin 15, Ireland
Telephone: +353 1 8612 632, Fax: +353 1 8612 647, email: sales@driveriteltd.com

W21-760-3459

VW Taro, Toyota Hilux

INSTALLATION INSTRUCTIONS

All work should be carried out in a properly equipped workshop with due regard to Health and Safety Regulations. No further reference to Health and Safety Regulations will be made, but they must be considered at all times.

The kit should be opened and the contents checked against the parts list provided. Identify the various components and familiarise yourself with them using drawings and information provided.

WARNING

Do not inflate this assembly when it is unrestricted. When installed, a minimum of 10 psi should be maintained in the air bellows at all times to avoid damage. Do not inflate beyond 100 psi.

IMPORTANT

This kit is not designed to increase the GVW of your vehicle. For your safety and to prevent possible damage to your vehicle, do not exceed the maximum load recommended by the vehicle manufacturer.



Full colour versions are available to download from our website at the following link

<http://www.driveriteltd.com/cimsgs/driverite/File/appdocs/3459.pdf>

Parts List

Description	Quantity
267 AIR SPRING	2
UPPER BRACKET	2
LOWER BRACKET	2
BRACKET STRAP	4
18 ft. TUBING	1
3/8"-16 X 3" CARRIAGE BOLT	8
3/8"-16 FLANGE LOCKNUT	12
3/8"-16 X 3/4" HEX BOLT	2

Description	Quantity
5/16"-18 BAIL CLAMP	4
5/16-18 FLANGE LOCKNUT	4
5/16" FLAT WASHER	4
ELBOW FITTING	2
INFLATION VALVE	2
NYLON TIES	6
THERMAL SLEEVE	2

PREPARATION:

In order for the kit to be installed on the vehicle, it is necessary firstly to provide free space within the range of the rear axle. There must be 20 mm clearance around each air spring. Usually, there are no additional components which could interfere with installing the kits in this space. However, if components are interfering with mounting the kit, then it must be clarified whether it is still possible to mount this kit or whether these additional parts can be moved accordingly. You must always take care not to interfere with the vehicle parts, e.g. brake hoses, cables etc. These could be jammed or damaged while assembling the kit. In order to ensure this does not occur, they must be partially shifted.



INSTALLATION

Raise the body of the vehicle until the wheels are approximately 50 mm above the ground, to allow space to insert the spring assemblies, which are mounted between axle and the chassis. Support the rear axle with a jack.



Pre fit the kit by mounting the Upper Bracket onto the spring using the 3/8" -16 flange locknuts. Attach the air fitting elbow to the airbag. Install the elbow in the air inlet hole on the top plate of the bellows. Tighten until the elbow is pointing towards the centre of the vehicle.

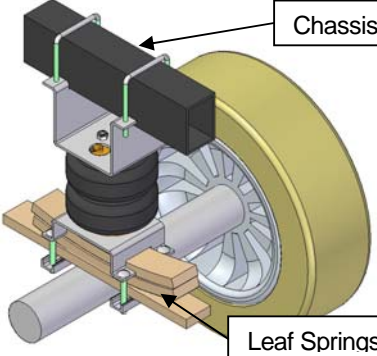

<p>Attach the lower bracket to the airbag using the 3/8 x 3/4 flange lock bolt. Next, cut the air line into two equal lengths, making the cut as square to the axis of the tubing as possible. Insert the air line into the elbow and push until a positive click is felt.</p>	
<p>Compress the air spring assembly and place it between the leaf spring and chassis rail. Using the 3/8"-16 X 3" carriage bolts and the Bracket straps fix the lower bracket to the axle. Attach the top bracket to the framework of the vehicle directly above the bottom bracket by means of the bail clamps provided, securing with the 5/16 nuts supplied.</p>	
<p>If the vehicle is fitted with ABS and Load Sensing Valve (LSV), then adjust the LSV to give maximum braking (1:1), by disconnecting the spring link between the rear axle and the LSV arm.</p> <p>If the vehicle is fitted with ABS and no LSV, then no brake adjustment is required. For vehicles without ABS, please contact us on +353 1 4507833 to request a brake modulation kit.</p>	
<p>Decide which side of the vehicle to mount the inflation valve: a suggested location is at the front or rear of the rear wheel arch. It should be easily accessible but protected, and on the same side of the vehicle as you intend to mount the pressure gauge (if applicable): a suitable location for this is inside the rear of the vehicle.</p>	
<p>Cut a generous length of air tubing to reach from the inflation valve to the top of the nearest air spring, following the line of the inner wheel arch and across to the top of the air spring, with sufficient slack to allow suspension movement. Insert one end of this tube into the air fitting in the air spring.</p> <p>Cut another generous length of air tubing to reach from the top of one air spring to the top of the other, routing it along the chassis so that it can be neatly held in place. Insert one end of this tube into the air fitting in the second air spring.</p> <p>Cut the tube between the inflation valve and the first air spring squarely close to the air spring and insert a T fitting between the 2 ends. Connect the tube from the air spring on the other side of the vehicle into the T fitting.</p>	

Drill an 8 mm (5/16") hole and mount the inflation valve as shown in the diagram, pushing the valve through the hole from behind and attaching with 2 washers and a nut.

Cut the air tube to length, making sure the end is cut squarely, and push the end as far as possible into the back of the inflation valve.

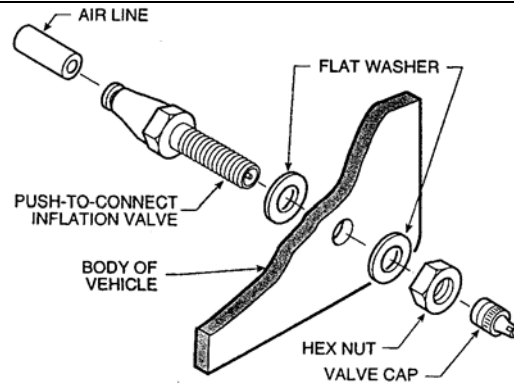

OPTION: To mount a pressure gauge inside the rear of the vehicle. Cut the air tube squarely a short distance back from the inflation valve, and insert the ends of the tubes into a Tee fitting. Cut a length of tube long enough to reach from the T fitting to the gauge. Feed the air tube up from below and connect the tube into the gauge and the Tee fitting.

IMPORTANT:

Do not attach to brake lines.

Protect the tube with the sleeving provided where there are any sharp edges or sources of heat.

Examination:

After assembly, inflate air bellows and check all mounting bolts are tight. Screw all connections tight again. It must be ensured that the mounting brackets can not move. If the plates touch the brake hose at the air spring, then these must be moved by suitable means.

Check for air leaks, using soapy water if necessary.

This completes the installation. To prevent possible damage, maintain a minimum of 20 psi in the air bellows at all times!

Empty: 0.5 bar up to max 5.0 bar

Loaded: 2.0 bar up to max 5.0 bar

FAILURE TO MAINTAIN MINIMUM PRESSURE WILL VOID YOUR WARRANTY