



Unit 626 Kilshane Avenue, North West Business Park, Ballycoolin, Dublin 15, Ireland
Telephone: +353 1 8612 632, Fax: +353 1 8612 647, email: sales@driveriteltd.com

W21-760-3123

Renault Master Semi Air Kit

Double Convoluted Version

INSTALLATION INSTRUCTIONS

All work should be carried out in a properly equipped workshop with due regard to Health and Safety Regulations. No further reference to Health and Safety Regulations will be made, but they must be considered at all times.

The kit should be opened and the contents checked against the parts list provided. Identify the various components and familiarise yourself with them using drawings and information provided.

WARNING

Do not inflate this assembly when it is unrestricted. When installed, a minimum of 10 psi should be maintained in the air bellows at all times to avoid damage. Do not inflate beyond 100 psi.

IMPORTANT

This kit is not designed to increase the GVW of your vehicle. For your safety and to prevent possible damage to your vehicle, do not exceed the maximum load recommended by the vehicle manufacturer.



PREPARATION:

In order for the kit to be installed on the vehicle, it is necessary firstly to provide free space within the range of the rear axle. Usually, there are no additional components which could interfere with installing the kits in this space. However, if components are interfering with mounting the kit, then it must be clarified whether it is still possible to mount this kit or whether these additional parts can be moved accordingly. You must always take care not to interfere with the vehicle parts, e.g. brake hoses, cables etc. These could be jammed or damaged while assembling the kit. In order to ensure this does not occur, they must be partially shifted.

Parts List

Description	Quantity	Description	Quantity
Airspring	2	Air Fitting	2
Upper Bracket	2	Tee Piece	1
Lower Bracket	2	Inflation Valve	2
3/8" Countersunk Screw	4	Cable Tie	10
U Bolt	2	Tubing	5m
3/8 Washer	4	Thermal Sleeve	2
3/8 Locknut	4		

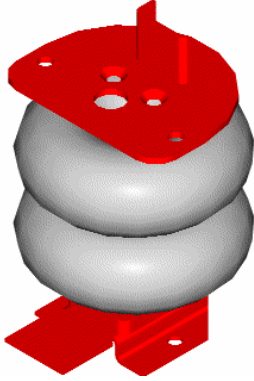
INSTALLATION

<p>Using 3/8 UNC x 1/2 " countersunk bolts assemble the top brackets to the airsprings. Screw in the elbow air fittings to the top of the airsprings. The use of thread sealant is recommended here.</p> <p>Using 3/8 UNC x 1" bolts, join the bottom brackets to the airsprings as shown, with the tongue at the bottom on the same side as the large air fitting hole at the top. Tighten the bolts. (See torque figures below).</p>	
<p>Remove the bump stops, but keep the bolts.</p>	
<p>Decide which side of the vehicle to mount the inflation valve: a suggested location is at the front or rear of the rear wheel arch. It should be easily accessible but protected, and on the same side of the vehicle as you intend to mount the pressure gauge (if applicable): a suitable location for this is inside the rear of the vehicle.</p> <p>Cut 2 lengths of air tube, 1200 mm and 300 mm. The shorter tube must be put on the same side as the inflation valve. Thread the tube into the chassis each side, entering the oval hole to the rear of the bump stop bolt hole and exiting the hole between the bolt holes.</p>	
<p>Insert the tube coming out between the bolt holes into the air fitting on the airspring and feed the whole airspring assembly up into chassis, with the tower on the inner side of the chassis rail. Secure the top bracket to the chassis with the original bump stop bolts. (To make this easier, compress the airspring and hold it with adhesive tape.)</p>	

Fit the bottom bracket on the axle tube and secure with u-bolts, nuts and washers. The tongue should just touch the spring.

Fully torque the U-bolts and bump stop bolts. (See torque figures below).



Route the longer air tube from the airspring along the underneath of the vehicle to the other side and connect with a Tee fitting to the tube from the other airspring.
Insert a length of air tube into the Tee fitting and run this tube to the location chosen for the inflation point.



Drill an 8 mm (5/16") hole and mount the inflation valve as shown in the diagram, pushing the valve through the hole from behind and attaching with 2 washers and a nut.

Cut the air tube to length, making sure the end is cut squarely, and push the end as far as possible into the back of the inflation valve.

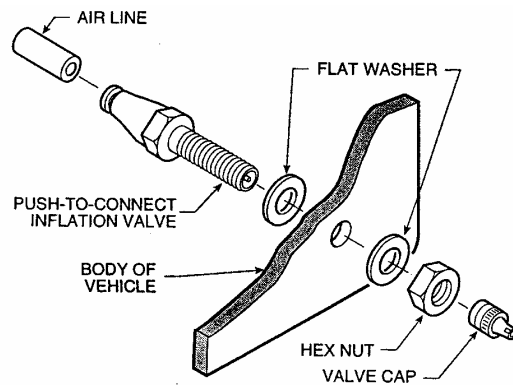

OPTION: To mount a pressure gauge inside the rear of the vehicle. Cut the air tube squarely a short distance back from the inflation valve, and insert the ends of the tubes into a Tee fitting. Cut a length of tube long enough to reach from the T fitting to the gauge. Feed the air tube up from below and connect the tube into the gauge and the Tee fitting.

IMPORTANT:

Attach all tubes securely to the vehicle using nylon ties.

Do not attach to brake lines.

Protect the tube with the sleeving provided where there are any sharp edges or sources of heat.

If the vehicle is fitted with ABS and Load Sensing Valve (LSV), then adjust the LSV to give maximum braking (1:1).

If the vehicle is fitted with ABS and no LSV, then no brake adjustment is required.

For vehicles without ABS, please contact us on +353 1 8612 632.

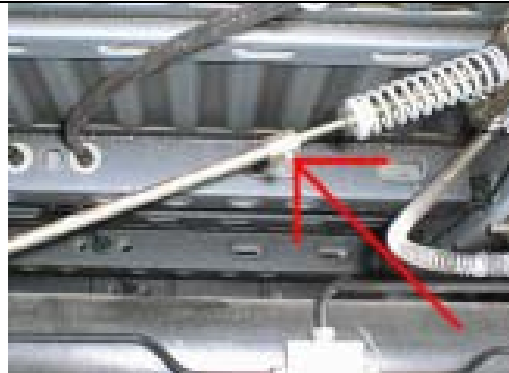

TORQUE SETTINGS

U bolts 3/8 UNC 38 Nm

10 mm bump stop bolts 50 Nm

Airspring bolts 3/8 UNC 25 Nm

Examination:

After assembly, inflate air bellows and check all mounting bolts are tight. Screw all connections tight again. It must be ensured that the mounting brackets can not move. If the plates touch the brake hose at the air spring, then these must be moved by suitable means.