



Unit 626 Kilshane Avenue, North West Business Park, Ballycoolin, Dublin 15, Ireland
 Telephone: +353 1 8612 632, Fax: +353 1 8612 647, email: sales@driveriteltd.com

W21-760-2455

INSTALLATION INSTRUCTIONS

All work should be carried out in a properly equipped workshop with due regard to Health and Safety Regulations. No further reference to Health and Safety Regulations will be made, but they must be considered at all times.

The kit should be opened and the contents checked against the parts list provided.

Identify the various components and familiarise yourself with them using drawings and information provided.

WARNING

Do not inflate this assembly when it is unrestricted. When installed, a minimum of 10 psi should be maintained in the air bellows at all times to avoid damage. Do not inflate beyond 100 psi.

IMPORTANT

This kit is not designed to increase the GVW of your vehicle. For your safety and to prevent possible damage to your vehicle, do not exceed the maximum load recommended by the vehicle manufacturer.

AIR SPRING	6781	2	3/8"-16 X 7" CARRIAGE BOLT	4
UPPER BRACKET	5569	2	3/8"-16 FLANGE LOCK NUT	12
LOWER BRACKET	5571	2	5/16" FLAT WASHER	4
FRAME CLAMP	5570	2	INFLATION VALVE	3032
SPACER	5568	2	MALE CONNECTOR	3046
BRACKET STRAP	5337	2	18 ft. TUBING	0938
BAIL CLAMP		2	THERMAL SLEEVE	
3/8"-16 X 3/4" HEX HEAD BOLT		2	NYLON TIE WRAP	
3/8"-16 X 3/4" FLAT HEAD BOLT		4	CAUTION TAG	

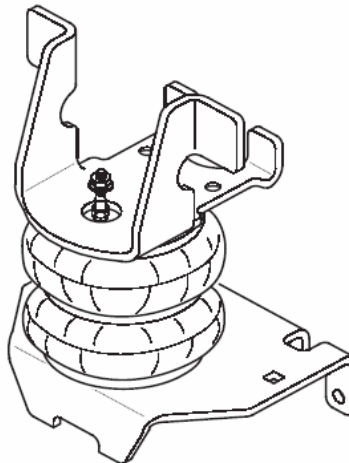
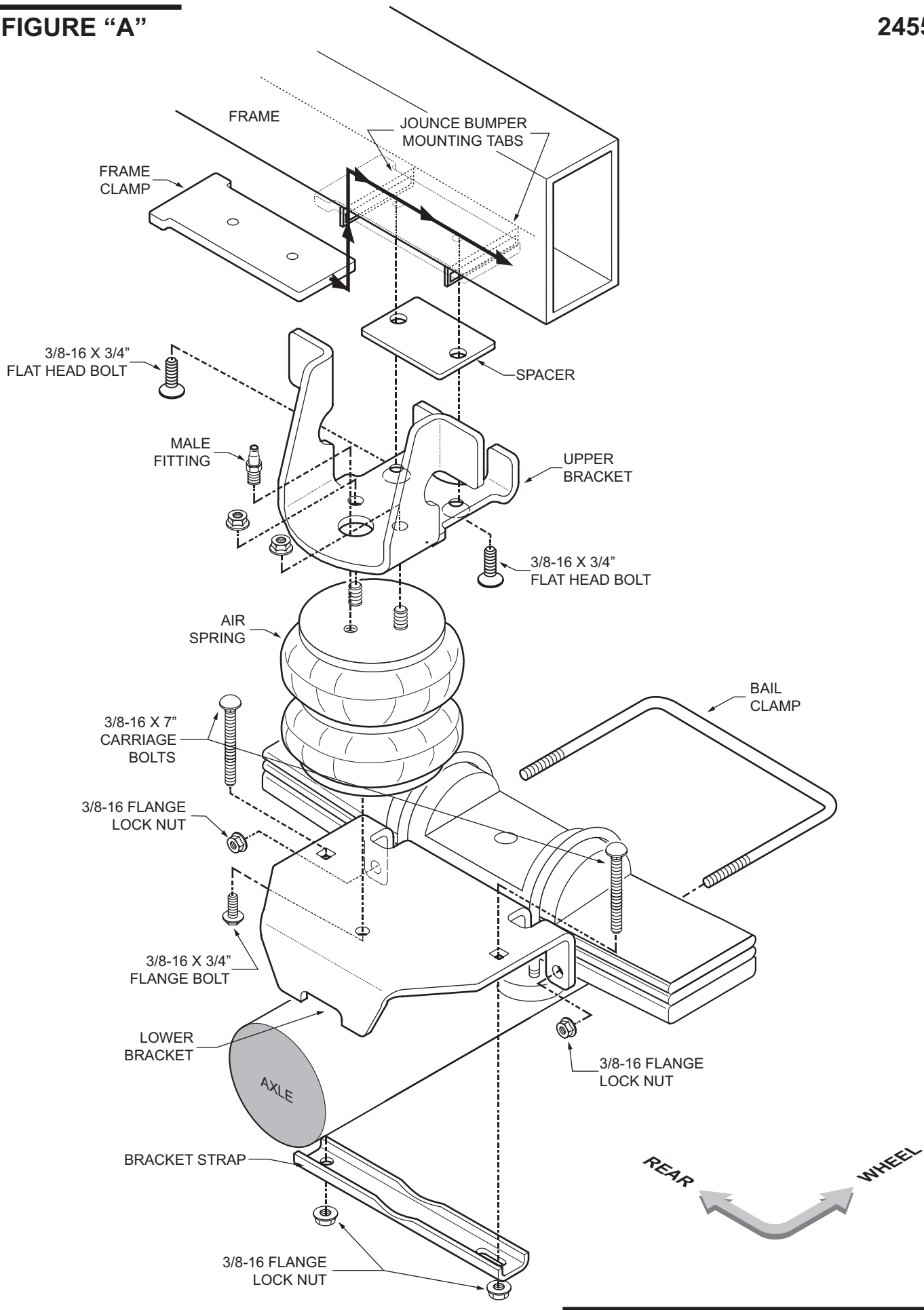

FIGURE "A"



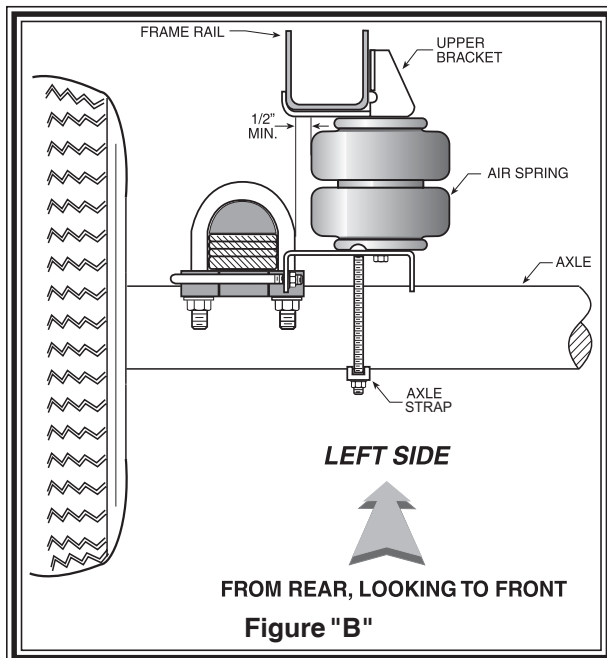

Figure "B"

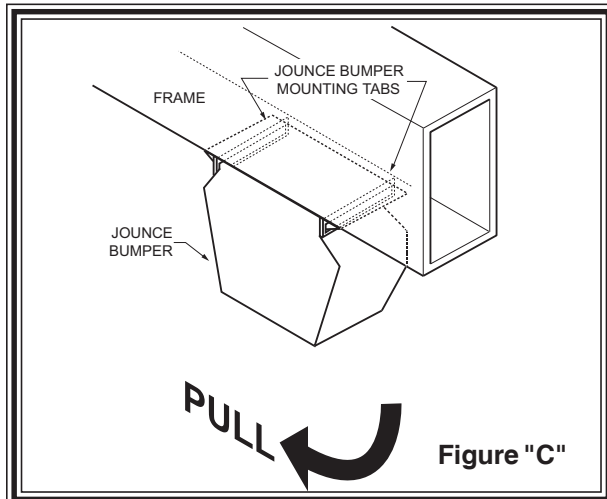

Figure "C"

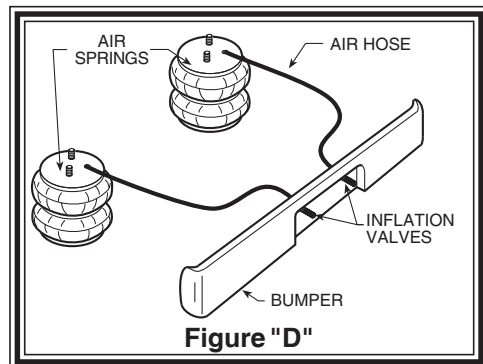

Figure "D"

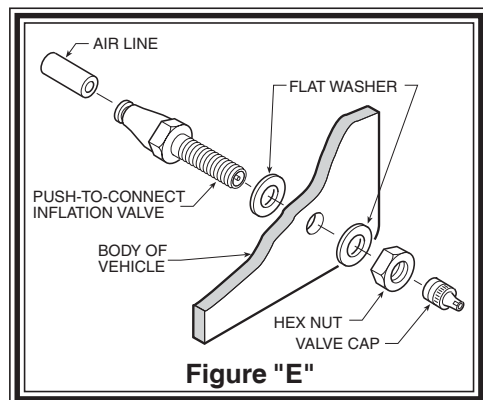

Figure "E"

NOTE: Please read through this manual completely before installing the air spring kit to your vehicle. All illustrations reference the left side of the vehicle. Reverse all orientations for the right side.

STEP 1 - PREPARE THE VEHICLE

With the vehicle on a solid, level surface, chock the front wheels. Raise the vehicle by the axle, remove the rear wheels, and lower the vehicle on to jack stands rated to your vehicles weight. Remove the negative battery cable.

Remove the vehicle's existing rubber jounce bumpers as shown in *Figure "C"*. The jounce bumpers will not be reused.

STEP 2 - UPPER BRACKET INSTALLATION

Slide the frame clamp into the jounce bumper mounting tabs on the bottom of the frame, from the rear of the vehicle, towards the front, *see Figure "A"*. Before the upper bracket is attached to the frame clamp, place the spacer on the upper bracket, then insert two 3/8"-16 X 3/4" flat head bolts through the upper bracket and the spacer. Next attach the upper bracket and spacer to the frame clamp. See *Figure "A"*.

STEP 3 - KIT ASSEMBLY INSTALLATION

Select one lower bracket and attach it to an air spring using a 3/8"-16 X 3/4" hex bolt. *See Figure "A"*. Insert two of the 3/8"-16 X 7" carriage bolts into the square holes in the lower bracket. Place the air spring assembly on the axle, making sure that the lower bracket captures the axle u-bolts. *See Figure "A"*. Insert a bracket strap onto the carriage bolts and install two 3/8"-16 flange lock nuts. *See Figure "A"*.

Next, insert the studs on the air spring into the small holes in the upper bracket, making sure the air inlet is visible through the large hole. *See Figure "A"*. Attach the air spring to the upper bracket using two of the 3/8"-16 flange lock nuts. Install the male fitting into the air inlet in the air spring. Tighten the air fitting securely to engage the orange thread sealant. *See Figure "A"*.

STEP 4 - INSTALLATION OF THE RIGHT SIDE

Follow steps 1-3 with reverse orientations for assembly and installation of the right side.

STEP 5 - INSTALL THE AIR LINE AND INFLATION VALVE

Uncoil the airline tubing and cut it into two equal lengths. *DO NOT FOLD OR KINK THE AIRLINE TUBING*. Try to make the cut as square as possible. Insert one end of the airline tubing into the air fitting installed in the top of the air helper spring. Push the airline tubing into the fitting as far as possible (*see Figure "A"*). Select a location on the vehicle for the air inflation valves. The location can be on the bumper or the body of the vehicle, as long as it is in a protected location so the valve will not be damaged, but maintain accessibility for the air chuck (*see Figure "D"*).

Drill a 5/16" hole and install the air inflation valve using two 5/16" flat washers per valve as supports (*see Figure "E"*). Run the airline tubing from the air helper spring to the valve, routing it to avoid direct heat from the engine, exhaust pipe, and away from sharp edges. Thermal sleeves have been provided for these conditions. The airline tubing should not be bent or curved sharply as it may buckle. Secure the airline tubing in place with the nylon ties provided. Push the end of the airline tubing into the inflation valve as illustrated (*see Figure "E"*).

STEP 6 - CHECK THE AIR SYSTEM

Once the inflation valves are installed, inflate the air helper springs to 70 *psi* and check the fittings for air leaks. Using a spray bottle, apply a solution of soap and water to the fittings. If a leak is detected at an airline tubing connection then check to make sure that the airline tube is cut as square as possible and that it is pushed completely into the fitting. The airline tubing can easily be removed from the fittings by exhausting all the pressure in the air springs and then pushing the collar towards the body of the fitting and then, with a gentle pull, remove the airline tubing. If a leak is detected where the air fitting screws into the spring, deflate the air springs and remove the tubing, then screw the air fitting into the air spring one additional turn or until the leak stops. Reinstall the tubing and re-inflate the air springs and check for leaks as noted above. This now completes the installation. With a load on your vehicle and the air helper springs inflated, you must have at least 1/2" clearance around the air springs. As a general rule, the air helper springs will support approximately 50 lbs. of load for each 1 *psi* of inflation pressure (per pair). For example, 50 *psi* of inflation pressure will support a load of 2500 lbs. per pair of air helper springs. **FOR BEST RIDE** use only enough air pressure in the air helper springs to level the vehicle when viewed from the side (front to rear). This amount will vary depending on the load, location of load, condition of existing suspension and personal preference.

NOTE: Too much air pressure in the air helper springs will result in a firmer ride, while too little air pressure will allow the air helper spring to bottom out over rough conditions. Too little air pressure will not provide the improvement in handling that is possible. **TO PREVENT POSSIBLE DAMAGE MAINTAIN A MINIMUM OF 5 *psi* IN THE AIR HELPER SPRINGS AT ALL TIMES.**

NOTE:

MIN PRESSURE

5 PSI

MAX PRESSURE (LOADED) 100 PSI

NOTE:

Should it become necessary to raise the vehicle by the frame, deflate both air helper springs completely. Reinflate the air springs after the vehicle is lowered to the ground.

