



Unit 626 Kilshane Avenue, North West Business Park, Ballycoolin, Dublin 15, Ireland  
 Telephone: +353 1 8612 632, Fax: +353 1 8612 647, email: sales@driveriteltd.com

## W21-760-2403

### INSTALLATION INSTRUCTIONS

All work should be carried out in a properly equipped workshop with due regard to Health and Safety Regulations. No further reference to Health and Safety Regulations will be made, but they must be considered at all times.

The kit should be opened and the contents checked against the parts list provided.

Identify the various components and familiarise yourself with them using drawings and information provided.

#### **WARNING**

*Do not inflate this assembly when it is unrestricted. When installed, a minimum of 10 psi should be maintained in the air bellows at all times to avoid damage. Do not inflate beyond 100 psi.*

#### **IMPORTANT**

*This kit is not designed to increase the GVW of your vehicle. For your safety and to prevent possible damage to your vehicle, do not exceed the maximum load recommended by the vehicle manufacturer.*

#### **PARTS LIST**

AIR SPRING	6766	2	3/8"-16 BAIL CLAMP		4
UPPER BRACKET	5483	2	5/16" FLAT WASHER		4
LOWER BRACKET	5484	2	MALE AIR FITTING	3055	2
BRACKET STRAP	5093	4	INFLATION VALVE	3032	2
18 ft. TUBING		1	NYLON TIES		6
3/8"-16 x 5 1/2" CARRIAGE BOLT		8	THERMAL SLEEVE		2
3/8"-16 FLANGE LOCK NUT		16			
3/8"-16 x 3/4" FLANGE BOLT		2			

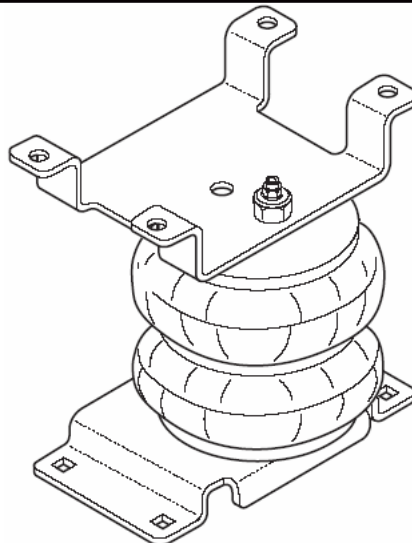

**NOTE:** Both illustrations are of the left, or driver's side of the vehicle.  
Reverse any orientations when assembling and installing the right, or passenger's side of the vehicle.

**FIGURE "A"**

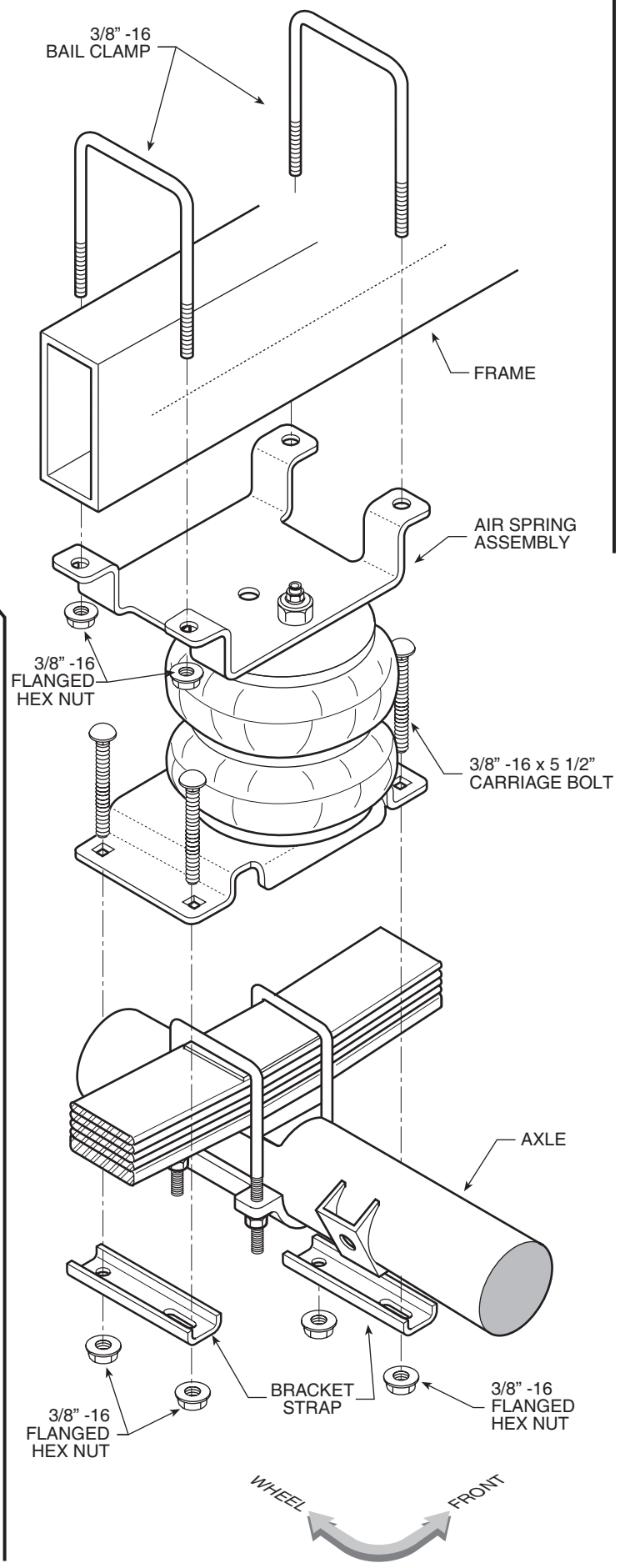
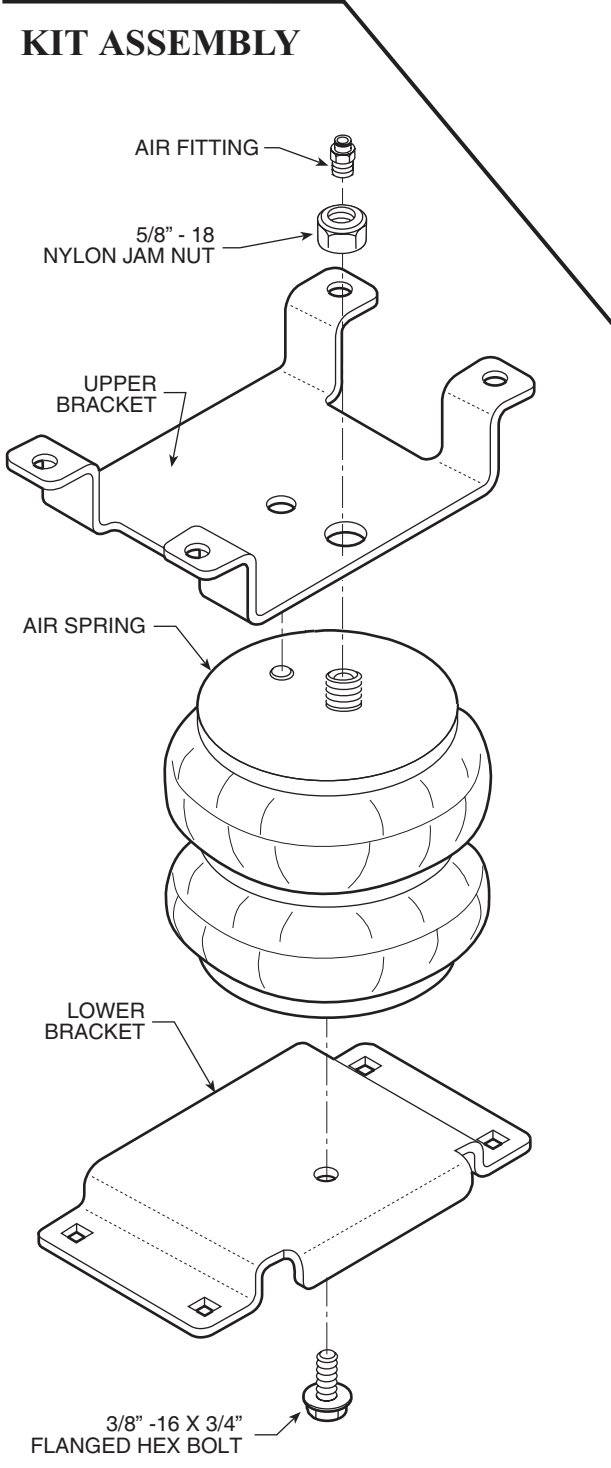

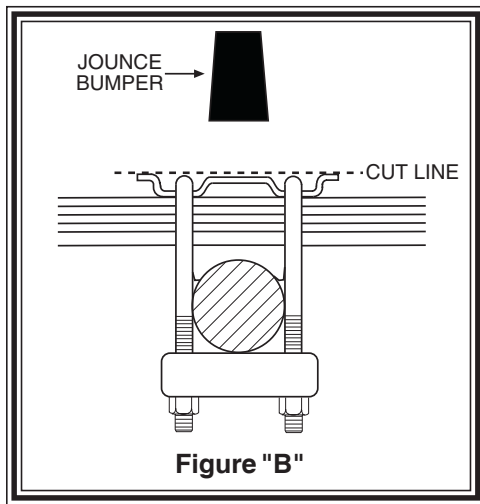

Figure "B"

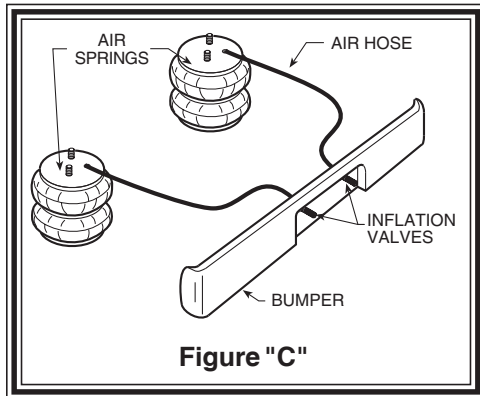

Figure "C"

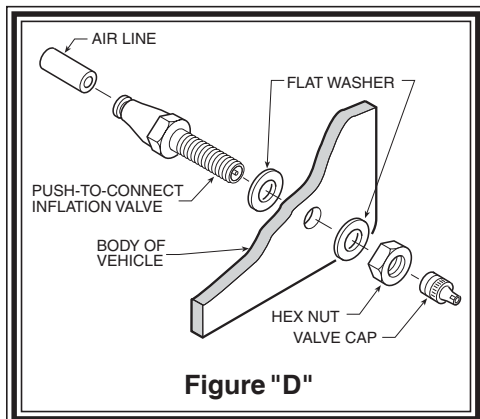

Figure "D"

### STEP 1 - PREPARE THE VEHICLE

Place the vehicle on a solid level surface. Take necessary safety precautions such as using wheel chocks when working under your vehicle. Remove the jounce bumpers by cutting them off as close to the bracket as possible as shown in *Figure "B"*.

### STEP 2 - PREASSEMBLE THE KIT

Select an upper bracket and an air spring from your kit. Attach the upper bracket to the air spring with a 5/8" nylock nut. Install the male fitting into the air spring. Tighten the air fitting securely to engage the orange thread sealant. No thread sealant is needed, (*see Figure "A"*). Attach the lower bracket to the air spring using the 3/8" - 16 x 3/4" hex bolt. Tighten the bolt making sure the bracket is in the correct position (*see Figure "A"*).

### STEP 3 - INSTALL THE PREASSEMBLY TO THE VEHICLE

Place the preassembly on the leaf stack of the left side of the vehicle as shown in *Figure "A"*. Attach the upper bracket directly beneath the frame rail using the 3/8" - 16 bail clamps and 3/8" lock nuts. Attach the lower bracket to the leaf stack using the 5 1/2" carriage bolts, 3/8" lock nuts, and bracket straps, (*see Figure "A"*).

Follow the same procedures as outlined in steps 1 through 3 for installing the right side of the vehicle.

### STEP 4 - INSTALL THE AIR LINE

Uncoil the air tubing and cut it into two equal lengths. **DO NOT FOLD OR KINK THE TUBING.** The air line tubing should not be bent or curved sharply as it may buckle with age. Make the cut as square as possible. Insert one end of the tubing into the elbow fitting installed in the top of the air helper spring.

Select a location on the vehicle for the air inflation valves. The locations can be on the bumper or the body of the vehicle but be sure that it is in a protected location so the valve will not be damaged yet still be accessible for the air chuck (*see Figure "C"*). Drill a 5/16" hole or use an existing hole and install the air inflation valve using two

5/16" stainless steel flat washers per valve as supports (*see Figure "D"*). Run the tubing from the air spring to the inflation valve, routing it to avoid direct heat from the muffler or tailpipe, and away from sharp edges. Tubing protectors have been provided for these conditions. Push the end of the air line tubing into the inflation valve as illustrated (*see Figure "D"*). Secure the tubing in place with the nylon ties provided.

### STEP 5 - CHECK THE AIR SYSTEM

Once the inflation valves are installed, inflate the air springs and check the fittings for air leaks with an applied solution of soap and water. If a leak is detected at a tubing connection then check to make sure that the tube is cut as square as possible and that it is pushed completely into the fitting. The tubing can easily be removed from the fittings by pushing the collar towards the body of the fitting and then pulling out the tube. If a leak is detected where the fitting screws into the spring, screw the elbow into the spring until the leak stops. Reinflate the air helper springs and check for leaks as noted above. Further information on trouble-shooting can be found in the General Operation Instruction book included with this kit.

