



Unit 626 Kilshane Avenue, North West Business Park, Ballycoolin, Dublin 15, Ireland  
 Telephone: +353 1 8612 632, Fax: +353 1 8612 647, email: sales@driveriteltd.com

## W21-760-2362

### INSTALLATION INSTRUCTIONS

All work should be carried out in a properly equipped workshop with due regard to Health and Safety Regulations. No further reference to Health and Safety Regulations will be made, but they must be considered at all times.

The kit should be opened and the contents checked against the parts list provided.

Identify the various components and familiarise yourself with them using drawings and information provided.

**WARNING**

*Do not inflate this assembly when it is unrestricted. When installed, a minimum of 10 psi should be maintained in the air bellows at all times to avoid damage. Do not inflate beyond 100 psi.*

**IMPORTANT**

*This kit is not designed to increase the GVW of your vehicle. For your safety and to prevent possible damage to your vehicle, do not exceed the maximum load recommended by the vehicle manufacturer.*

#### Parts List

Description	Quantity
267Air Spring 6781	2
Left Upper Bracket 5429	1
Right Upper Bracket 5430	1
Lower Bracket 5426	2
Bracket Strap 5086	2
18ft Tubing	1
3/8" – 16X4 1/2" Carriage Bolt	4
3/8-16 Flange Locknut	12

Description	Quantity
3/8-16 x 3/4 Flange Hex Bolt	2
3/8" Special Washer	4
3/8-16 X 1 1/2 Hex Bolt	4
5/16 Flat Washer	4
Elbow Fitting	2
Inflation Valve	2
Thermal Sleeve	2
Nylon Tie	6



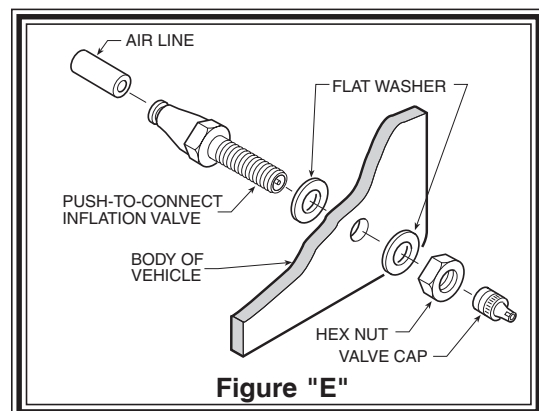
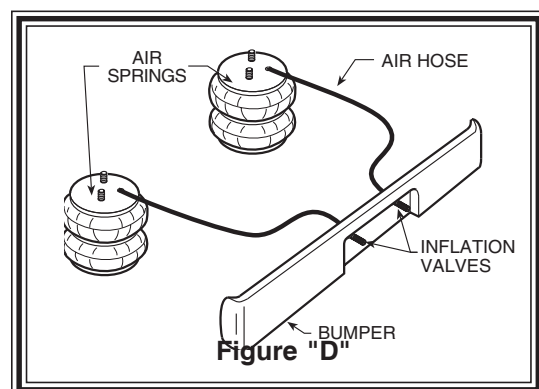
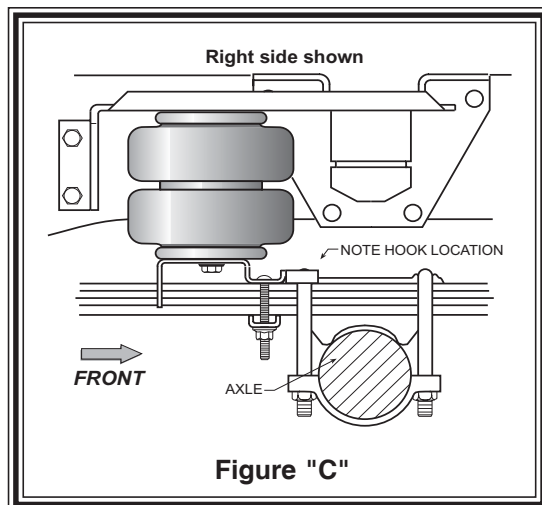
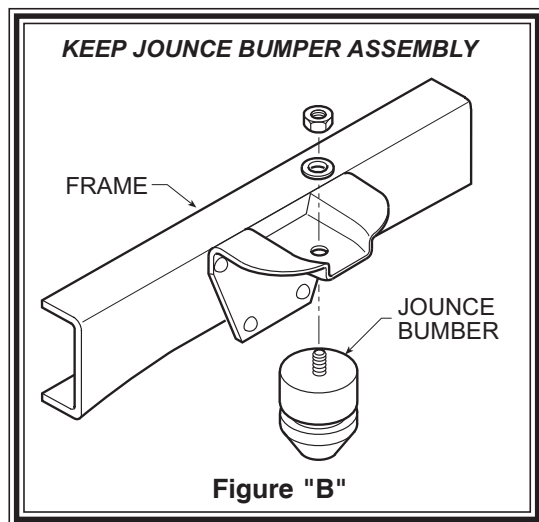

### STEP 1 - PREPARE THE VEHICLE

With the vehicle on a solid, level surface chock the front wheels. Raise the vehicle by the rear axle and remove the rear wheels. After the removal of the wheels lower the vehicle so the axle rests on jack stands rated for your vehicles weight. Make sure the negative battery cable is disconnected from the battery.

### STEP 2 - PREASSEMBLE THE RIDE-RITE KIT

Select one air helper spring from your kit and an upper bracket. Align the studs on the air spring with the holes on the upper bracket making sure the air inlet hole can be seen through the slot in the upper bracket *see Figure "A"*. Use the 3/8"-16 flange lock nuts to secure the upper bracket to the air spring. Install the elbow fitting into the air spring through the large access hole in the upper bracket. Tighten the air fitting securely to engage the orange thread sealant. Position the fitting to point to the anticipated location of the air inflation valves. Position the lower bracket as shown in *Figure "A"* & *"C"* utilizing the outside hole, fasten the lower bracket to the air helper spring using a 3/8"-16 flange bolt (*finger tight*).

### STEP 3 - PRE-FIT MARK AND DRILL HOLES

Remove the jounce bumper from the bracket on the side of the frame rail as shown in *Figure "B"*. Make sure to keep the jounce bumper and all attaching components. These parts will be used later in this step. Set the air spring assembly onto the leaf stack and align the hole in the upper bracket with the hole from the jounce bumper removal refer to *Figure "A"*. Re-install the jounce bumper using all original components, this will attach the upper bracket to the jounce bumper bracket (tighten). With the upper bracket securely in place using a center punch mark the two holes that will be drilled on the frame rail. The upper bracket flange will work as a template for marking the holes to be drilled. ***Before drilling the holes make sure all electrical, brake and fuel lines are cleared from the path of the drill.*** Damage to lines can be avoided by inserting a piece of wood between the frame rail and any lines in the path of the drill. Drill the two holes in the frame rail using a 3/8" drill bit *see Figure "A"*.

### STEP 4 - INSTALLATION TO THE VEHICLE

After drilling the holes in the frame rail install the 3/8"-16 x 1 1/2" hex bolts through the upper bracket holes and the holes that were drilled in the frame rail. Next fasten the upper bracket to the frame rail using the 3/8"-16 flange lock nuts and special flat washers to the back side of the frame rail refer to *Figure "A"*. The next step is to attach the lower bracket to the leaf spring assembly. Insert (2) of the 4 1/2" carriage bolts making sure the lower bracket hook captures the forward "U"-bolt. The carriage bolts should straddle the leaf stack refer to *Figure "A"* & *"C"*. Slide the bracket strap onto the carriage bolts as to clamp the lower bracket to the leaf stack *see Figure "A"* and *"C"*. Fasten using the 3/8"-16 flange lock nuts. Tighten the 3/8"-16 flange bolt that holds the air spring to the lower bracket using an open end wrench.

## **STEP 5 - INSTALLATION TO THE PASSENGER'S SIDE ASSEMBLY**

Follow steps 1-4 for assembly and installation of the left side assembly.

## **STEP 6 - INSTALL THE AIR LINE AND THE INFLATION VALVE**

Uncoil the air line tubing and cut it into two equal lengths. **DO NOT FOLD OR KINK THE TUBING.** Try to make the cut as square as possible. Insert one end of the tubing into the elbow fitting installed in the top of the air helper spring. Push the tubing into the fitting as far as possible refer to **Figure "A"**.

Select a location on the vehicle for the air inflation valves. The location can be on the bumper or the body of the vehicle, as long as it is in a protected location so the valve will not be damaged, but maintain accessibility for the air chuck **see Figure "D"**. Drill a 5/16" hole and install the air inflation valve using two 5/16" flat washers per valve as supports **see Figure "E"**. Run the tubing from the air helper spring to the inflation valve, routing it to avoid direct heat from the engine, exhaust pipe, and away from sharp edges. Thermal sleeves have been provided for these conditions. If a thermal sleeve is required simply slide the sleeve over the air line tubing to the location requiring protection. The air line tubing should not be bent or curved sharply as it may buckle. Secure the tubing in place with the nylon ties provided. Push the end of the air line tubing into the inflation valve as illustrated **see Figure "E"**.

## **STEP 7 - CHECK THE AIR SYSTEM**

Once the inflation valves are installed inflate the air helper springs to **70 P.S.I.** and check the fittings for air leaks with an applied solution of soap and water. If a leak is detected at a tubing connection then check to make sure that the tube is cut as square as possible and that it is pushed completely into the fitting. The tubing can easily be removed from the fittings by pushing the collar towards the body of the fitting and then pulling out the tube. If a leak is detected where the fitting screws into the spring, screw the elbow into the spring until the leak stops. Reinflate the air springs and check for leaks as noted above. Further information on trouble-shooting can be found in the General Operation Instruction book included with this kit.

This now completes the installation. Install the wheels and torque the lug nuts to the manufactures specifications. Raise the vehicle by the rear axle and remove the jack stands and lower the vehicle back onto the ground. Re-attach the negative battery cable and remove the wheel chocks from the rear wheels. Before proceeding, check once again to be sure you have proper clearance around the air springs. With a load on your vehicle and the air helper springs inflated, you must have at least 1/2" clearance around the air springs. As a general rule, the Ride-Rite Air Helper Springs will support approximately 40 lbs. of load for each P.S.I. of inflation pressure (per pair). For example, 50 P.S.I. of inflation pressure will support a load of 2400 lbs. per pair of air helper springs. **FOR BEST RIDE** use only enough air pressure in the air helper springs to level the vehicle when viewed from the side (front to rear). This amount will vary depending on the load, location of load, condition of existing suspension and personal preference.

### **NOTE:**

Too much air pressure in the air helper springs will result in a firmer ride, while too little air pressure will allow the air helper spring to bottom out over rough conditions. Too little air pressure will also not provide the improvement in handling that is possible. **TO PREVENT POSSIBLE DAMAGE MAINTAIN A MINIMUM OF 10 P.S.I. IN THE RIDE-RITE AIR HELPER SPRINGS AT ALL TIMES.**

Enclosed with this kit are Ride-Rite Operating Instructions. Please read them for proper and safe operation.

### **NOTE:**

Once the air helper springs are installed, it is recommended that the vehicle not be lifted by the frame, as over-extension may occur, resulting in damage to the air helper springs. However, should it become necessary to raise the vehicle by the frame, deflate both air helper springs completely.

