



Unit 626 Kilshane Avenue, North West Business Park, Ballycoolin, Dublin 15, Ireland
 Telephone: +353 1 8612 632, Fax: +353 1 8612 647, email: sales@driveriteltd.com

W21-760-2350

INSTALLATION INSTRUCTIONS

All work should be carried out in a properly equipped workshop with due regard to Health and Safety Regulations. No further reference to Health and Safety Regulations will be made, but they must be considered at all times.

The kit should be opened and the contents checked against the parts list provided.

Identify the various components and familiarise yourself with them using drawings and information provided.

WARNING

Do not inflate this assembly when it is unrestricted. When installed, a minimum of 10 psi should be maintained in the air bellows at all times to avoid damage. Do not inflate beyond 100 psi.

IMPORTANT

This kit is not designed to increase the GVW of your vehicle. For your safety and to prevent possible damage to your vehicle, do not exceed the maximum load recommended by the vehicle manufacturer.

AIR SPRING	6397	2	3/8"-16 X 3/4" HEX HEAD BOLT	2
RIGHT UPPER BRACKET	5409	1	3/8"-16 x 5 1/2" CARRIAGE BOLTS	4
LEFT UPPER BRACKET	5410	1	5/8"-18 NYLON JAM NUT	2
LOWER BRACKETS	5412	2	3/8"-16 BAIL CLAMP	2
LOWER BRACE	5413	2	10mm X 30mm FLAT HEAD ALLEN BOLT	2
HEAT SHIELD	0025	1	5/16" FLAT WASHER	4
AXLE STRAP	0530	2	INFLATION VALVE	2
AIR LINE TUBING		1	AIR FITTING	2
3/8"-16 FLANGE LOCK NUT		12	THERMAL SLEEVE	2
3/8"-16 X 1" HEX HEAD BOLT		4	NYLON TIE	6

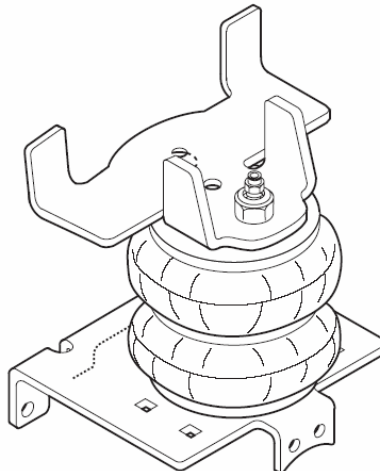
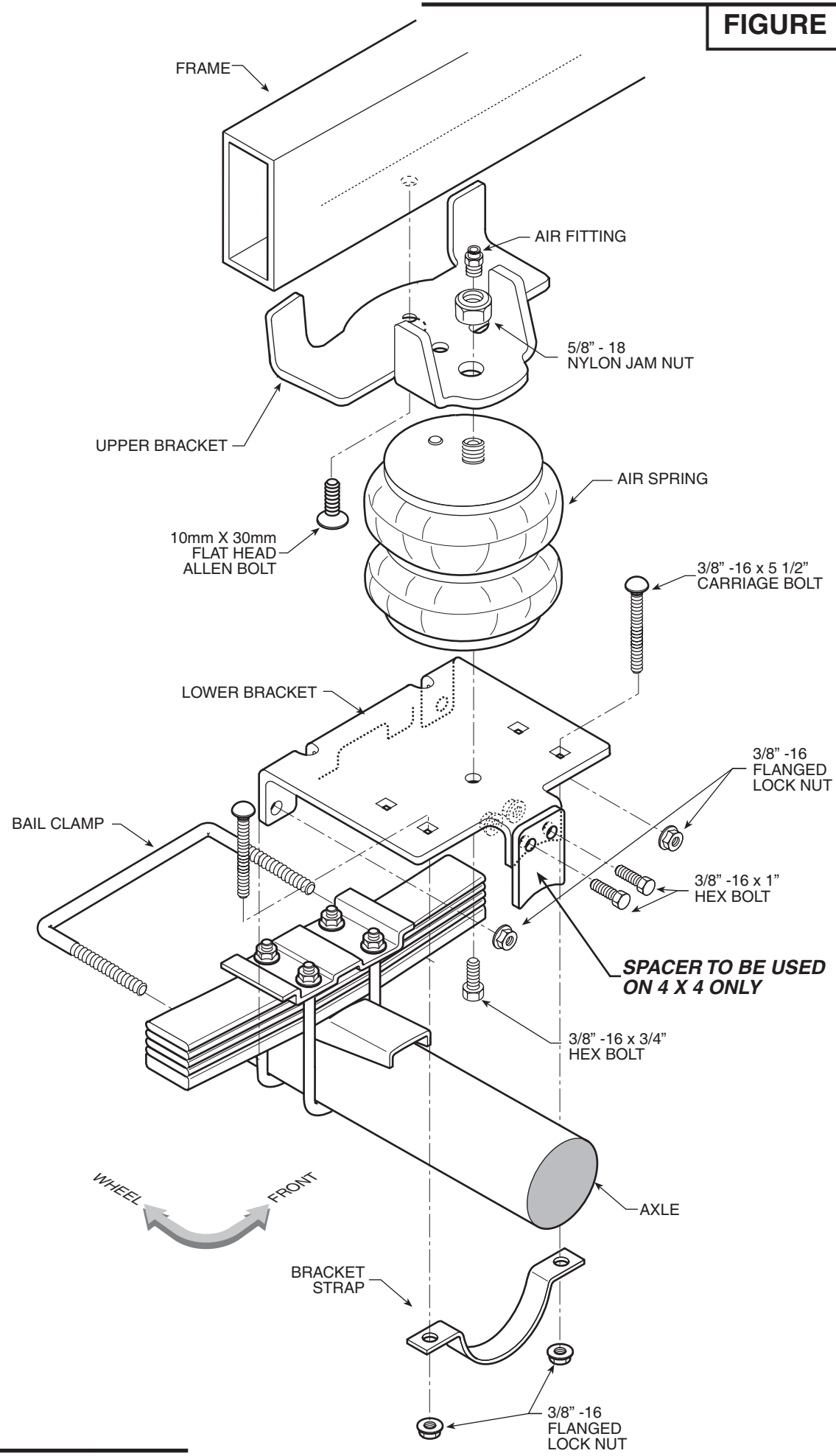
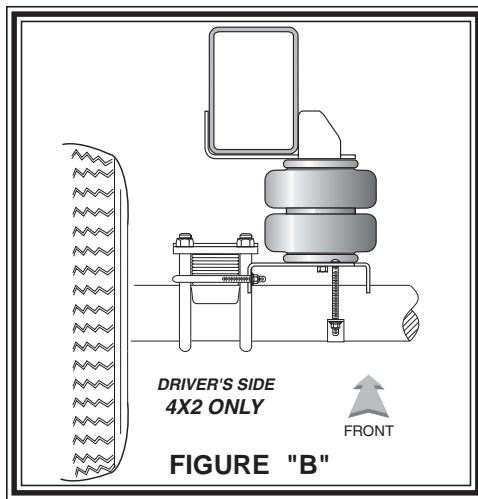

FIGURE "A"





STEP 1 - PREPARE THE VEHICLE

Remove the negative battery cable. With the vehicle on a solid, level surface chock the front wheels. Raise the vehicle by the rear axle and remove the rear wheels. After the removal of the wheels lower the vehicle so the axle rests on jack stands rated for your vehicles weight. Remove the jounce bumper located under the frame rail.

STEP 2 - PREASSEMBLE THE KIT

Select one air helper spring and an lower bracket from your kit. Next, place the 3/8"-16 x 5 1/2" carriage bolts into the square holes on the lower bracket. Fasten the lower bracket using a 3/8"-16 x 3/4" hex head bolt finger tight. *See Figure "A"*.

STEP 3 - UPPER BRACKET INSTALLATION

Install the upper bracket on the frame using the 10mm x 30mm flat head allen bolt, *see Figure "A"*. This will be located where the jounce bumper was removed. Attach the air spring to the upper bracket with the 5/8"-18 Nylon jam nut. The combination stud will use the inner most hole and the "button" on the air spring will be aligned with the outer most hole on the upper bracket (*see Figure "A"*). *Note: On the exhaust side of the truck, a heat shield will be required. Please see heat shield manual.* Install the air fitting into the air spring and tighten securely to engage the orange thread sealant, *see Figure "A"*.

STEP 4 - LOWER BRACKET INSTALLATION

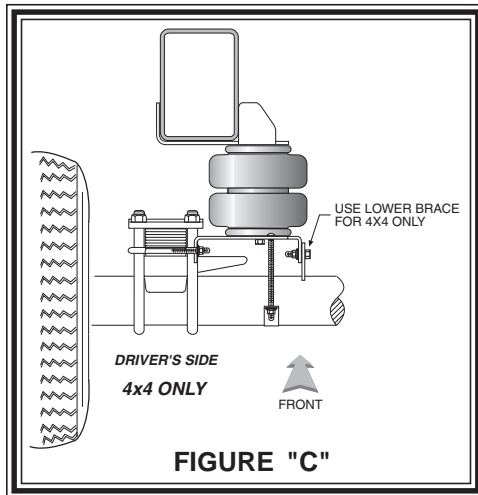

The lower bracket will rest on the axle with the outer portion placed between the U-bolts that hold the leaf stack to the axle. Insert the bail clamp into the two holes on the lower bracket from outside the leaf stack and secure with the 3/8"-16 hex nuts (*Figures "A" & "B"*) Push the axle strap onto the carriage bolts from the underside of the axle and secure it using the 3/8"-16 hex nuts *see Figure "A"*.

On 4X4 modles, attach the lower brace to the lower bracket using the 3/8-16 x 1" hex head bolts and 3/8-16 hex nuts, *see Figures "A" & "C"*. The lower bracket will rest on the "tong" instead of the axle. The rest of the attachments are the same (*Figure "A"*).

After everything is aligned, tighten the 3/8"-16 hex bolt on the bottom of the air spring.

STEP 5 - INSTALLATION TO THE PASSENGER'S SIDE ASSEMBLY

Reverse any orientations when assembling and installing the right, or passenger, side of the vehicle.

STEP 6 - INSTALL THE AIR LINE AND THE INFLATION VALVE

Uncoil the air line tubing and cut it into two equal lengths. *DO NOT FOLD OR KINK THE TUBING.* Try to make the cut as square as possible. Insert one end of the tubing into the elbow fitting installed in the top of the air helper spring. Push the tubing into the fitting as far as possible.

Select a location on the vehicle for the air inflation valves. The location can be on the bumper or the body of the vehicle, as long as it is in a protected location so the valve will not be damaged, but maintain accessibility for the air chuck, *see Figure "F"*. Drill a 5/16" hole and install the air inflation valve using two 5/16" flat washers per valve as supports, *see Figure "E"*. Run the tubing from the air helper spring to the inflation valve, routing it to avoid direct heat from the engine, exhaust pipe, and away from sharp edges. Thermal sleeves have been provided for these conditions. If a thermal sleeve is required simply slide the sleeve over the air line tubing to the location requiring protection. The air line tubing should not be bent or curved sharply as it may buckle. Secure the tubing in place with the nylon ties provided. Push the end of the air line tubing into the inflation valve as illustrated, *see Figure "E"*.

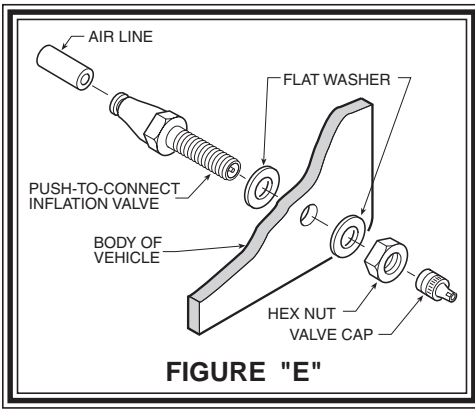

STEP 7 - CHECK THE AIR SYSTEM

Once the inflation valves are installed inflate the air helper springs to 70psi and check the fittings for air leaks with an applied solution of soap and water. If a leak is detected at a tubing connection then check to make sure that the tube is cut as square as possible and that it is pushed completely into the fitting. The tubing can easily be removed from the fittings by pushing the collar towards the body of the fitting and then pulling out the tube. If a leak is detected where the fitting screws into the spring, screw the fitting into the air spring until the leak stops. Reinstall the tubing and reinflate the air springs and check for leaks as noted above.

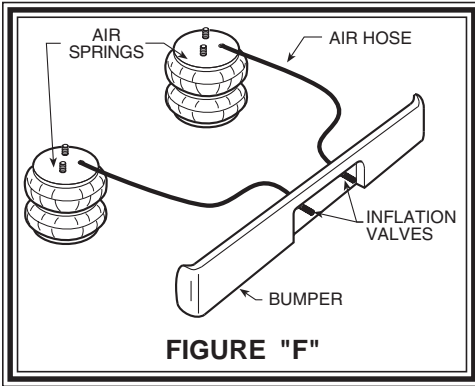

This now completes the installation. Install the wheels and torque the lug nuts to the manufactures specifications. Raise the vehicle by the rear axle and remove the jack stands and lower the vehicle back onto the ground. Re-attach the negative battery cable and remove the wheel chocks from the wheels. Before proceeding, check once again to be sure you have proper clearance around the air springs. With a load on your vehicle and the air helper springs inflated, you must have at least 1/2" clearance around the air springs. As a general rule, the air helper springs will support approximately 40 lbs. of load for each psi of inflation pressure (per pair). For example, 50 psi of inflation pressure will support a load of 2000 lbs. per pair of air helper springs. *FOR BEST RIDE* use

only enough air pressure in the air helper springs to level the vehicle when viewed from the side (front to rear). This amount will vary depending on the load, location of load, condition of existing suspension and personal preference.

NOTE:

Too much air pressure in the air helper springs will result in a firmer ride, while too little air pressure will allow the air helper spring to bottom out over rough conditions. Too little air pressure will also not provide the improvement in handling that is possible. **TO PREVENT POSSIBLE DAMAGE MAINTAIN A MINIMUM OF 5psi IN THE AIR HELPER SPRINGS AT ALL TIMES.**

Once the air helper springs are installed, it is recommended that the vehicle not be lifted by the frame, as over-extension may occur, resulting in damage to the air helper springs. However, should it become necessary to raise the vehicle by the frame, deflate both air helper springs completely.

