

## SINGLE ELECTRONIC CONTROL KIT

### INSTALLATION INSTRUCTIONS

Congratulations on your purchase of a new Single Electronic Control kit. This kit was designed to provide inflation control of your air helper springs. This kit will be an asset to your vehicle, meeting nearly all of your air supply needs.

Please take a few minutes to read through the instructions, identify the components, and learn how to properly install your Single Electronic Control kit.

### NOTE:

The Single Electronic Control kit can be used with all air helper spring products. If you are installing an air suspension system, do not install the air line tubing to the air springs as stated in the suspension system instruction manual. If you are adding the Single Electronic Control kit to an existing air suspension system, you will need to deflate the air springs and remove the air line tubing.

### NOTE OF CONNECTION THE AIRLINE TUBING

Cut the air line tubing as squarely as possible. To connect the air line tubing to the fittings, push the tubing into the fittings as far as possible. If for any reason the tubing must be removed, first release the air pressure from the air helper spring. Push the collar toward the body of the fitting and then pull out the tubing. To reassemble, make sure the tubing is cut squarely and push the tubing back into the fitting.

### TOOLS NEEDED:

- |                      |                     |
|----------------------|---------------------|
| Center Punch         | 3/8" Electric Drill |
| 3/16 Drill Bit       | 1/4" Drill Bit      |
| Wire Crimpers        | 2 - 7/16" Wrenches  |
| 3/8" Wrench          | 10mm Wrench         |
| Phillips Screwdriver | Flat Screwdriver    |
| Hacksaw              |                     |

### PARTS LIST

HEIGHT CONTROL VALVE	7529	1	LINK ARM	1
AIR COMPRESSOR	9285	1	M5 JAM NUT	2
30 FT. AIR LINE	9008	1	3/16" FLAT WASHER	9
WIRE HARNESS	9276	1	10-32 BOLT	6
SOLENOID	9107	1	#10 WASHER	6
COMPRESSOR T-FITTING	3066	1	10-32 NUT	6
HOSE CLAMP		1	1/4"-20 x 1" HEX BOLT	2
PUSH-TO-CONNECT			1/4" FLAT WASHER	2
T-FITTING	3025	1	1/4"-20 HEX NUT	2



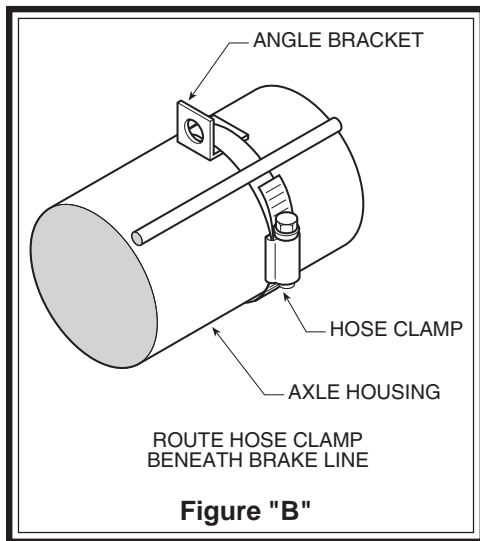

### **STEP 1 – PREPARE THE COMPRESSOR AND EXHAUST VALVE**

Install the Compressor tee fitting into the threaded output port on the compressor head, *see Figure “A”*. Tighten the fitting sufficiently to engage at least two threads with the pre-applied thread sealant. **DO NOT OVERTIGHTEN THE FITTING.** Install the exhaust valve into the female end of the “T” fitting. Tighten the exhaust valve sufficiently to engage to thread sealant. Crimp a female spade terminal to both wires coming out of the exhaust valve.

### **STEP 2– MOUNT THE COMPRESSOR**

Begin by removing the negative battery cable. Select a convenient location to mount the compressor. This location should provide ample air flow and be protected from airborne debris and moisture. The mounting surface should be rigid to support the compressor. Make sure that the wire harness will reach from the compressor to the anticipated location of the height control sensor. The compressor is oil-less and can be mounted in any orientation necessary for installation.

Mark the four compressor mounting holes using the compressor as a template and center punch, and then drill four 3/16" holes. Any burrs in the holes should be removed to prevent damaged to the rubber isolators. Mount the compressor using the supplied 10-32 x 1" machine screws, 10-32 lock nuts and 3/16" washers.

Attach the black wire from the compressor to a convenient ground source on the vehicle. Most any metal connection point common to the vehicle frame should be suitable.

### **STEP 3 – SELECT A LOCATION FOR THE HEIGHT CONTROL SENSOR**

Review *Figure “A” and “C”* to become familiar with the installation of the height sensor. The height control sensor should be mounted on the frame rail or body of the vehicle. The height control sensor must be in a location that will allow the link-arm to reach the axle housing and be attached without any interference. The sensor-arm on the height control sensor must have enough clearance to operate freely throughout the full 100 degree range of motion. Caution: The sensor arm can not travel past the mechanical stops or permanent damage to the sensor will accrue (*see Figure “C”*).

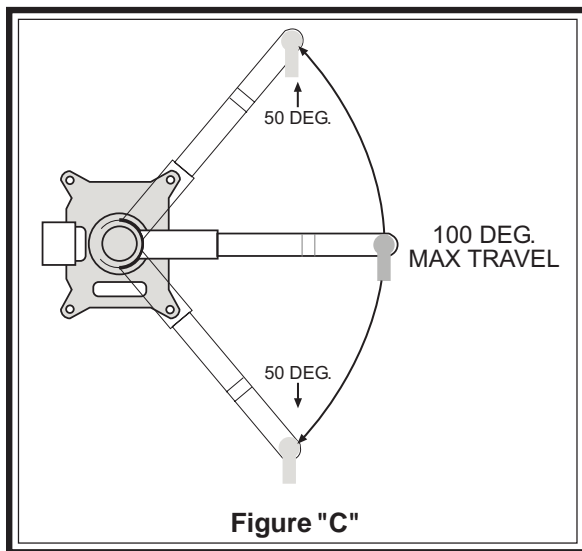

### **STEP 4– MOUNT THE HEIGHT CONTROL SENSOR**

Mount the height control sensor in a location where it may be attached to the frame so that the arm extends over the axle. The sensor must be in a location where the link-arm can reach from the sensor to the axle housing. The height control sensor can be attached directly to the frame rail above the axle. To attach the height control sensor to the frame, use the mounting holes on the sensor as a template to mark and drill two 1/4" holes. Use the 1/4"-20 x 1" hex bolts, 1/4"-20 nuts and 1/4" lock washers to secure the sensor to the frame.

### **STEP 5 – MOUNT THE ANGLE BRACKET**

Place the angle bracket on the axle directly beneath the sensor arm. This bracket does not have to be on top of the axle. Find a location free from obstructions, such as brake lines. Place the hose clamp around the axle and the angle bracket and tighten the clamp. Ensure that the hose clamp does not clamp over the brake line, as to avoid damage to the line, *see Figures “A” & “B”*.

### **STEP 6 – ATTACH THE LINK-ARM**

Measure the distance from the angle bracket on the axle to the linkage on the sensor arm. Ensure that the arm on the height control sensor is aligned horizontally. Layout the linkage with the same distance measured above. If the threaded rod is too long it can be cut to length using a hacksaw. Install the M5 jam nut over both ends of the threaded rod, cut if needed, and then install the linkage on both ends of the rod. Connect the rod to the linkage on the sensor arm and the linkage on the axle bracket. The linkages can be screwed up or down on the shaft for fine adjustment of the height control sensor.

### **STEP 7 – ROUTE THE AIR LINE TUBING**

Cut a piece of air line tubing that will reach from the compressor to the air springs. Cut the air line tubing as squarely as possible and inset the tubing into the push-to-connect “T” fitting on the compressor. Insert the other end of the air line tubing

into the other push-to-connect “T” fitting. Run the air line tubing from both ends of the “T” fitting to the air springs, *see Figure “A”*. Do not fold or kink the air line tubing. Use the tie wraps included in the kit to secure the air line tubing to the vehicle.

### ***STEP 8 – ROUTE THE WIRE HARNESS***

Insert the Packed connector into the height control sensor. Attach the black wire from the wire harness next to the Packard connector to a convenient ground source on the vehicle. Most any metal connection point common to the vehicle frame should be suitable. Route the wire harness to the compressor and the exhaust valve. Use the tie wraps included in the kit to secure the wire harness to the vehicle. Mount the relays in a dry area around the compressor. Connect the black wire from the exhaust valve to the black wire in the wire harness. Connect the yellow/green wire from the exhaust valve to the yellow wire in the wire harness. Connect the red wire from the compressor to the red/black wire off the relay. Both red wires coming out of the wire harness should be attached to a positive 12V D.C. supply capable of handling 20Amps. The blue wire has to be connected to a 12V D.C. supply that is an ignition controlled circuit, *see Figure “A”*. Consult your dealer or vehicle owners manual for wiring diagrams.

### ***TEST THE SYTEM***

This now completes the installation. Re-attach the negative battery cable to the battery. When the vehicle is loaded, the height control sensor will detect the reduction in ride height. The compressor will inflate your air springs until the proper ride height is achieved. When the load is removed, the air springs will automatically be deflated to achieve a normal ride height. If your vehicle does not achieve the desired ride height, the length of the link-arm may be increased or decreased.

Note that after a load has been placed on or removed from the vehicle there will be a delay of a few seconds before the height control sensor responds to the change in ride height.



**FIRESTONE INDUSTRIAL PRODUCTS COMPANY**  
**12650 HAMILTON CROSSING BOULEVARD**  
**CARMEL, IN 46032**  
**1-800-888-0650**