



Unit 626 Kilshane Avenue, North West Business Park, Ballycoolin, Dublin 15, Ireland
 Telephone: +353 1 8612 632, Fax: +353 1 8612 647, email: sales@driveriteltd.com

W21-760-2312

INSTALLATION INSTRUCTIONS

All work should be carried out in a properly equipped workshop with due regard to Health and Safety Regulations. No further reference to Health and Safety Regulations will be made, but they must be considered at all times.

The kit should be opened and the contents checked against the parts list provided.

Identify the various components and familiarise yourself with them using drawings and information provided.

WARNING

Do not inflate this assembly when it is unrestricted. When installed, a minimum of 10 psi should be maintained in the air bellows at all times to avoid damage. Do not inflate beyond 100 psi.

IMPORTANT

This kit is not designed to increase the GVW of your vehicle. For your safety and to prevent possible damage to your vehicle, do not exceed the maximum load recommended by the vehicle manufacturer.

PARTS LIST

AIR SPRING	9002	2	PUSH-TO-CONNECT		
LEFT UPPER FRAME BRACKET	5345	1	INFLATION VALVE	3098	2
RIGHT UPPER FRAME BRACKET	5346	1	VALVE CAP		2
LEFT UPPER			THERMAL SLEEVE	0899	2
AIR SPRING BRACKET	5368	1	5/16"-18 X 1" HEX BOLT		4
RIGHT UPPER			5/16"-18 FLANGE NUT		4
AIR SPRING BRACKET	5367	1	5/16" FLAT WASHER		4
LEFT INNER BRACKET	5347	1	3/8"-16 X 1" HEX BOLT		8
RIGHT INNER BRACKET	5348	1	3/8"-16 X 3/4" FLANGE BOLT		6
SPACER	5366	4	3/8"-16 X 3 1/2 HEX BOLT		2
LOWER BRACKET	5349	2	3/8"-16 X 2 1/2" CARRIAGE BOLT		4
JOUNCE BUMPER SPACER	5350	2	3/8"-16 X 5 1/2" CARRIAGE BOLT		4
BRACKET CLAMP	5086	2	3/8"-16 FLANGE NUT		1 8
AXLE CLAMP	5181	2	3/8" FLAT WASHER		2
FRAME SLEEVE	5392	2	3/8" LARGE FLAT WASHER		2
18 ft. TUBING	0938	1	NYLON TIE WRAP		6
PUSH-TO-CONNECT			CAUTION TAG		2
ELBOW	3101	2			

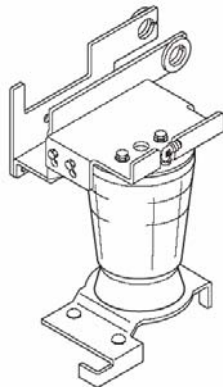

2292 / 2312

FIGURE "A"

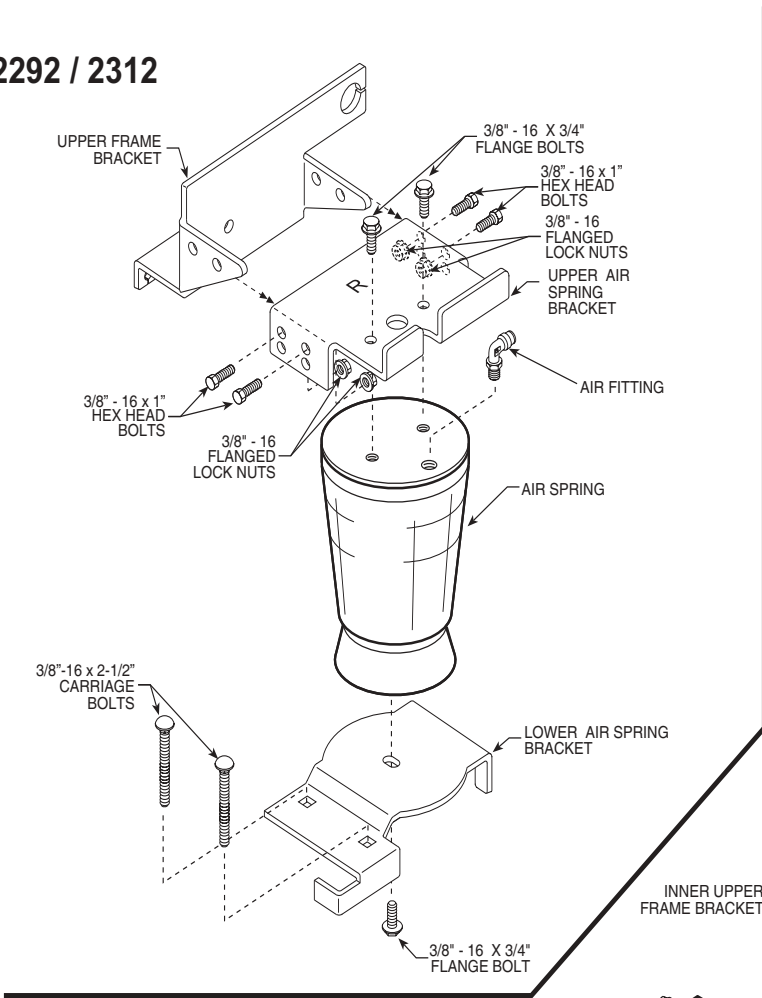

NOTE: Both illustrations are of the right side, of the van. Refer to Step 3 for the proper lower bracket alignment.

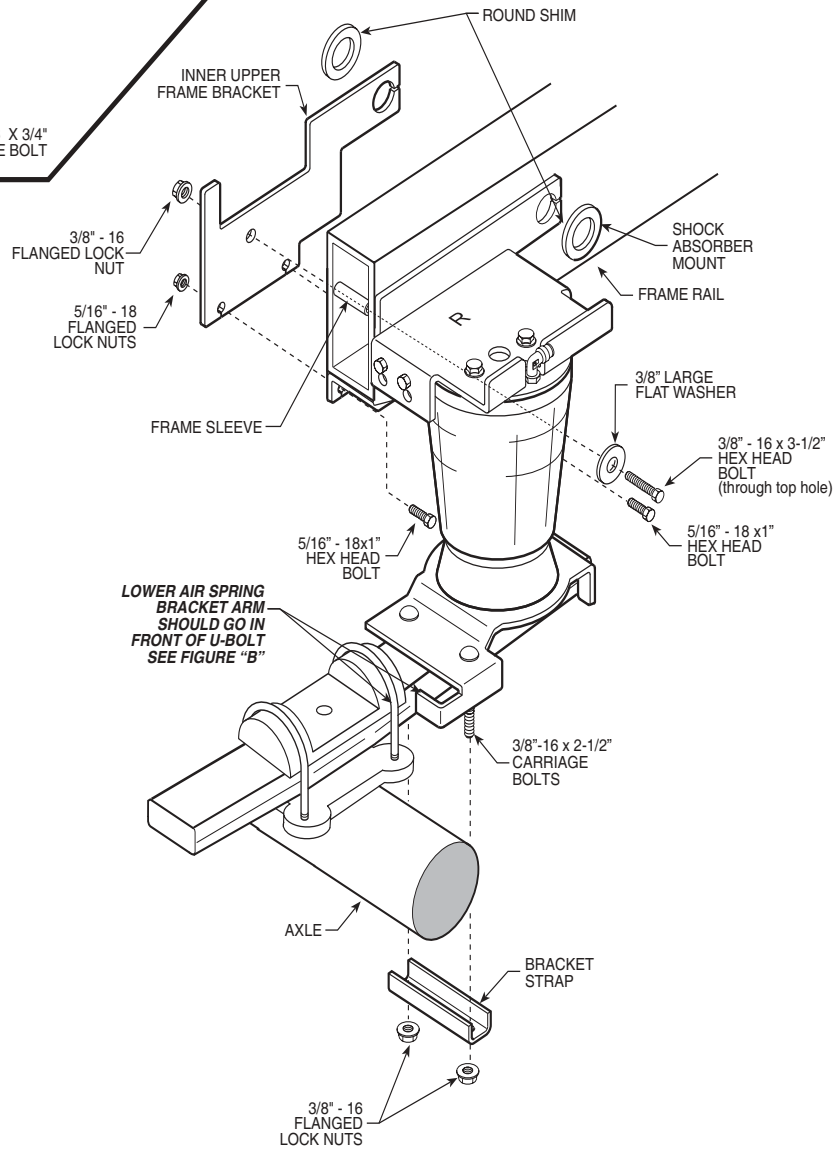

NOTE:

Please read through this manual completely before installing the air spring kit to your vehicle.

STEP 1 - PREPARE THE VEHICLE

With the vehicle on a solid, level surface chock the front wheels. Raise the vehicle by the axle and remove the back wheels. After the removal of the wheels lower the vehicle so the axle rests on jack stands rated for your vehicles weight. Remove the negative battery cable.

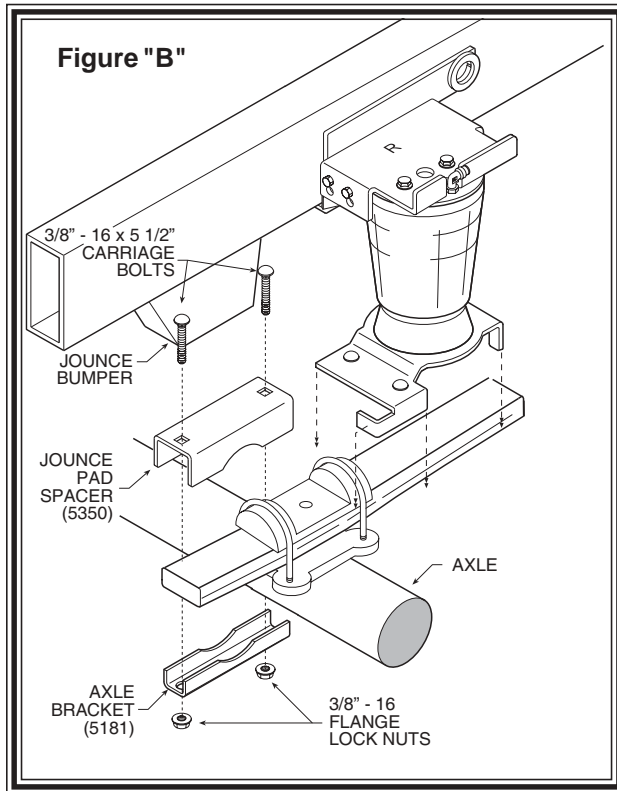
**STEP 2 - PRE-ASSEMBLE THE KIT**

Note: The upper frame brackets and the upper air spring brackets are marked “R” and “L” to indicate right side and left side.

Select the upper air spring bracket marked “R” and the upper frame bracket marked “R” from the kit. Assemble the upper air spring bracket and the upper frame bracket using four 3/8”-16 x 1” hex head bolts and four 3/8”-16 flange nuts, as shown in Figure “A”.

STEP 3 - INSTALLING THE ASSEMBLY TO THE VEHICLE

Remove the shock absorber top bolt and move the top of the shock absorber out of the way. Place the upper bracket assembly on the frame rail and around the shock absorber mount. Place the round shim on the outside of the bracket on the shock absorber mount. Then place the inner upper bracket marked “R” on the inside of the frame rail and around the shock absorber mount. Fasten the inside frame bracket and outside bracket assembly together with two 5/16”-18 x 1” hex head bolts and 5/16”-16 flange lock nuts. Place the round shim on the outside of the inner frame bracket on the shock absorber mount. Reinstall the shock absorber and tighten the shock absorber bolt back to manufacturer’s specifications. Using the upper brackets as a template drill one 3/8” hole on the inside of the frame and a 5/8 hole on the outside

of the frame. **Before drilling the hole make sure electrical, brake and fuel lines are cleared from the path of the drill.** In order to prevent any damage to these lines it is recommended that a piece of wood be placed between the frame rail and the existing lines. Install the 3/8”-16 x 3 1/2” hex head bolt, frame sleeve, large flat washer, and secure with a 3/8”-16 flange lock nut.

Select one air spring from your kit and install the swivel elbow push to connect fitting. Tighten the air fitting so as to make contact with the nylon ring and tighten 1/4 turn to snug the fitting. No thread sealant is needed. Fasten the air spring to upper bracket the using the 3/8”-16 x 3/4” flanged lock bolts, see Figure “A”.

Select one lower bracket from your kit. Insert the 3/8”-16 x 2 1/2” carriage bolts into the square holes on the lower bracket. Fasten the air spring to the lower bracket using the 3/8”-16 x 3/4” flange bolt (*finger tight*), see Figure “A”. Attach the lower bracket to the leaf stack using the carriage bolts (installed earlier), the flange lock nuts and bracket strap as shown in Figure “A”. Tighten up the 3/8”-16 x 3/4” flange bolt in the bottom of the air spring that was installed earlier. Once the assembly is in place make sure that you have a minimum of a 1/2” clearance around the air spring for proper operation.

STEP 4 - INSTALLATION OF THE JOUNCE BUMPER PAD SPACER

A jounce pad spacer will have to be added to the axle. Select a jounce bumper space and a axle clamp bracket from your kit. Attach the jounce pad space below the jounce bumper with two 3/8”-16 x 3 1/2” carriage bolts and two 3/8”-16 flange lock nuts, please see Figure “B”.

STEP 5 - INSTALLATION OF THE LEFT SIDE ASSEMBLY

Follow steps 2-4 with reverse orientations for assembly and installation of the right side assembly.

STEP 6 - INSTALL THE AIRLINE TUBING AND INFLATION VALVE

Uncoil the airline tubing and cut it into two equal lengths. **DO NOT FOLD OR KINK THE AIRLINE TUBING.** Try to make the cut as square as possible. Insert one end of the airline tubing into the air fitting installed in the top of the air helper spring. Push the airline tubing into the fitting as far as possible see Figure “A”.

Select a location on the vehicle for the air inflation valves. The location can be on the bumper or the body of the vehicle, as long as it is in a protected location so the valve will not be damaged, but maintain accessibility for the air chuck *see Figure "C"*. Drill a 5/16" hole and install the air inflation valve using two 5/16" flat washers per valve as supports *see Figure "D"*. Run the airline tubing from the air helper spring to the valve, routing it to avoid direct heat from the engine, exhaust pipe, and away from sharp edges. Thermal sleeves have been provided for these conditions. The airline tubing should not be bent or curved sharply as it may buckle. Secure the airline tubing in place with the nylon ties provided. Push the end of the airline tubing into the inflation valve as illustrated *see Figure "D"*.

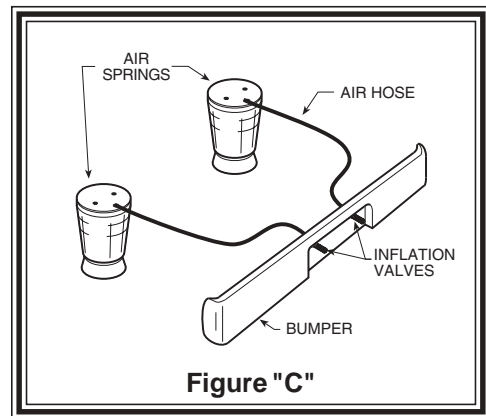

Figure "C"

STEP 7 - CHECK THE AIR SYSTEM

Once the inflation valves are installed, inflate the air helper springs to 70 psi and check the fittings for air leaks. Using a spray bottle, apply a solution of soap and water to the fittings. If a leak is detected at a airline tubing connection then check to make sure that the airline tubing is cut as square as possible and that it is pushed completely into the fitting. The airline tubing can easily be removed from the fittings by exhausting all the pressure in the air springs and then pushing the collar towards the body of the fitting and then, with a gentle pull, remove the airline tubing. Reinstall the tubing and reinflate the air springs and check for leaks as noted above. If a leak is detected where the air fitting screws into the spring, deflate the air springs, then screw the air fitting into the air spring until the leak stops. Reinstall the tubing and reinflate the air springs and check for leaks as noted above.

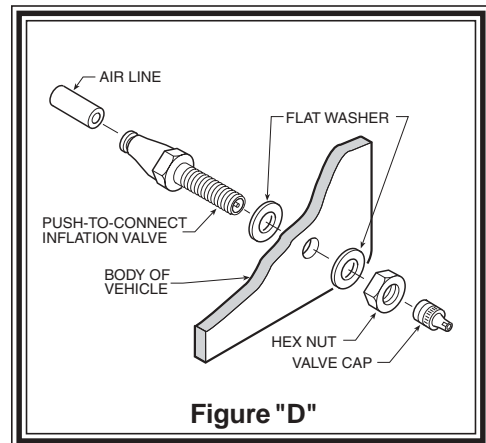

Figure "D"

This now completes the installation. Install the wheels and torque the lug nuts to the manufacturer's specification. Raise the vehicle by the axle and remove the jack stands. Lower the vehicle to the ground. Reattach the negative battery cable and remove the wheel chocks from the front wheels. Before proceeding, check once again to be sure you have proper clearance around the air springs. With a load on your vehicle and the air helper springs inflated, you must have at least 1/2" clearance around the air springs. As a general rule, the air helper springs will support approximately 30 lbs. of load for each psi of inflation pressure (per pair). For example, 50 psi of inflation pressure will support a load of 1000 lbs. per pair of air helper springs. *FOR BEST RIDE* use only enough air pressure in the air helper springs to level the vehicle when viewed from the side (front to rear). This amount will vary depending on the load, location of load, condition of existing suspension and personal preference.

NOTE:

Too much air pressure in the air helper springs will result in a firmer ride, while too little air pressure will allow the air helper spring to bottom out over rough conditions. Too little air pressure will not provide the improvement in handling that is possible. **TO PREVENT POSSIBLE DAMAGE MAINTAIN A MINIMUM OF 10 psi IN THE AIR HELPER SPRINGS AT ALL TIMES.**

NOTE:

Once the air helper springs are installed, it is recommended that the vehicle not be lifted by the frame, as over-extension may occur, resulting in damage to the air helper springs. However, should it become necessary to raise the vehicle by the frame, deflate both air helper springs completely.

