



Unit 626 Kilshane Avenue, North West Business Park, Ballycoolin, Dublin 15, Ireland
 Telephone: +353 1 8612 632, Fax: +353 1 8612 647, email: sales@driveriteltd.com

W21-760-2299

INSTALLATION INSTRUCTIONS

All work should be carried out in a properly equipped workshop with due regard to Health and Safety Regulations. No further reference to Health and Safety Regulations will be made, but they must be considered at all times.

The kit should be opened and the contents checked against the parts list provided.

Identify the various components and familiarise yourself with them using drawings and information provided.

WARNING

Do not inflate this assembly when it is unrestricted. When installed, a minimum of 10 psi should be maintained in the air bellows at all times to avoid damage. Do not inflate beyond 100 psi.

IMPORTANT

This kit is not designed to increase the GVW of your vehicle. For your safety and to prevent possible damage to your vehicle, do not exceed the maximum load recommended by the vehicle manufacturer.

PARTS LIST

AIR SPRING	6401	2	THERMAL SLEEVE	0899	2
UPPER BRACKET	5369	2	3/8"-16 BAIL CLAMP	3292	2
LOWER BRACKET	5370	2	5/16" FLAT WASHER		4
AXLE BRACKET	5181	2	3/8"-16 X 3/4" FLANGE LOCK		2
HEAT SHIELD	1004	1	3/8"-16 FLANGE NUT		4
18 ft. TUBING	0938	1	3/4"-16 HEX NUT		2
PUSH-TO-CONNECT INFLATION VALVE	3098	2	3/4" STAR WASHER		2
VALVE CAP		2	10MM X 30MM FLAT HEAD BOLT		4
PUSH-TO-CONNECT FITTING	3100	2	NYLON TIE WRAP		6
			CAUTION TAG		2

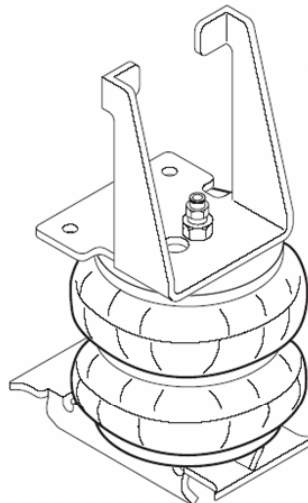
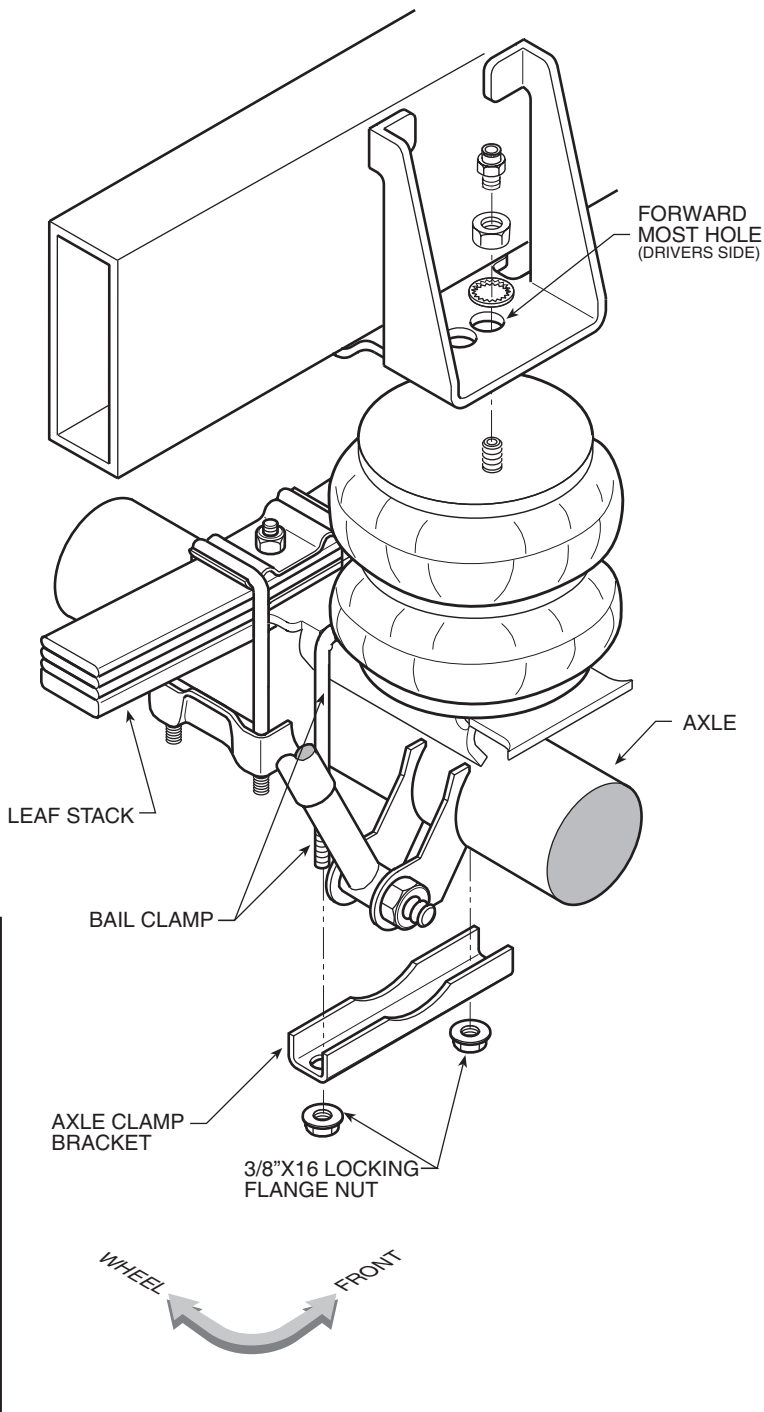

FIGURE "A"

NOTE: Both illustrations are of the left, or drivers side, of the vehicle. Reverse any orientations when assembling and installing the right, or passenger, side of the vehicle.

NOTE: 2WD SHOWN, USE SAME PROCEDURES ON 4WD.



KIT ASSEMBLY

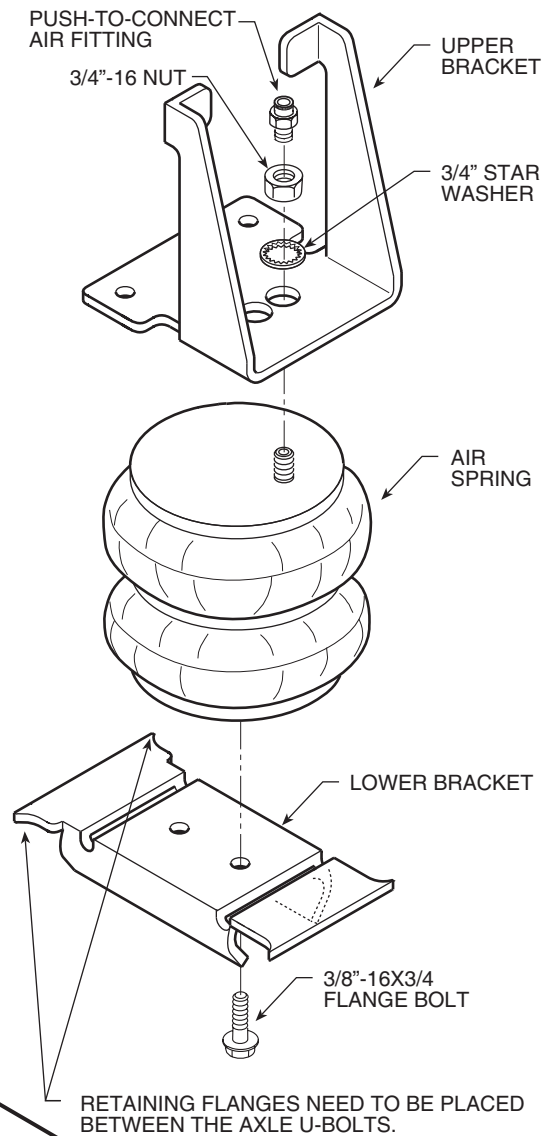

Lower Bracket Orientation

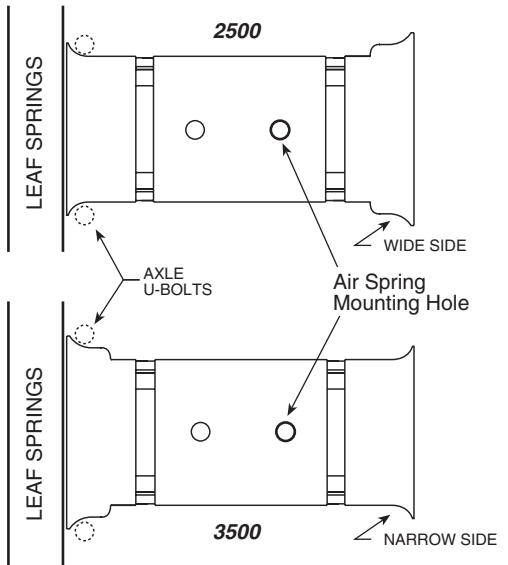

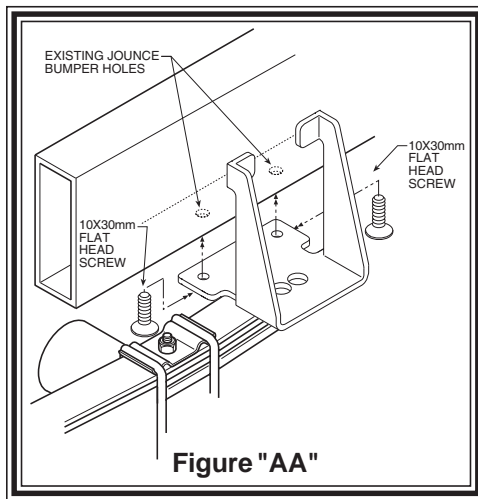

Figure "AA"

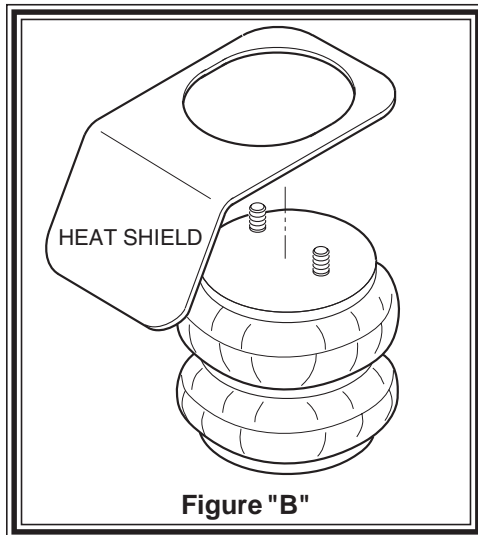

Figure "B"

NOTE:

Please read through this manual completely before installing the air spring kit to your vehicle.

STEP 1 - PREPARE THE VEHICLE

With the vehicle on a solid, level surface chock the front wheels. Remove the positive battery cable. Your vehicle is equipped with rubber jounce bumpers. The jounce bumpers are bolted to the frame above the axle. Remove the jounce bumpers from the vehicle.

STEP 2 - PRE-ASSEMBLE THE KIT

This kit contains two identical lower brackets that are designed to fit either axle diameter available on your vehicle. Select a lower bracket from your kit and determine which side of the bracket fits most snugly between the axle U-bolts as shown in *Figure "A"*. **NOTE: The two different widths on the ends of the bracket.** It will be necessary to tilt the bracket to properly slide the brackets retaining flange between the U-bolts and the leaf stack. Remove the bracket from the axle and mark which side fit between the U-bolts. Select one air spring from the kit and install the air spring to the lower bracket with one 3/8-16 X 3/4" flange head bolt finger tight, *see Figure "A"*. Next, install the push to connect air fitting in the top threaded hole in the air spring. Tighten the air fitting so as to make contact with the nylon ring and then tighten 1/4 turn to snug fitting. No thread sealant is needed.

STEP 3 - INSTALLING THE ASSEMBLY TO THE VEHICLE

Select an upper bracket from the kit and install it in place of the jounce bumper using two 10mm X 30mm flat head screws tightened securely, *see Figure "AA"*. Position the lower bracket and air spring assembly from Step 2 on the axle as shown in *Figure "A"*. Make sure the large threaded stud on the top of the air spring protrudes **through the forward most hole** of the two holes in the upper bracket. Fasten the lower bracket to the axle housing using the bail clamp and the axle clamp bracket and two 3/8"-16 locking flange nuts securely, *see Figure "A"*. The bail clamp should fit in the locating notches in the lower bracket. Attach the

top of the air spring with the 3/4-16 hex nut and 3/4" star washer. You must maintain a minimum of 1/2" clearance around the air spring for proper operation. Once the bracket orientation has been set, tighten the 3/8"-16x3/4" hex head bolt in the lower bracket securely.

STEP 4 - INSTALLATION OF THE PASSENGER'S SIDE ASSEMBLY

Follow steps 1-3 with reverse orientations for assembly and installation of the passenger's side assembly. The heat shield is mounted between the upper bracket and the top plate of the air spring, *see Figure "B"*. Position the heat shield directly between the closest heat source and the air spring. Ensure that the heat shield will not interfere with normal operation of the air spring or the vehicle's suspension. Do not position the heat shield directly above the axle, as it may contact the axle on full suspension travel.

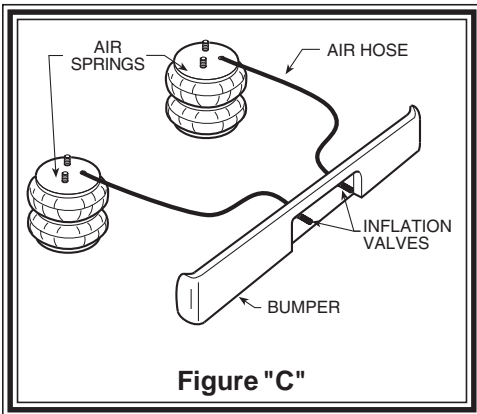

Figure "C"

STEP 5 - INSTALL THE AIR LINE AND INFLATION VALVE

Uncoil the airline tubing and cut it into two equal lengths. *DO NOT FOLD OR KINK THE AIRLINE TUBING.* Try to make the cut as square as possible. Insert one end of the airline tubing into the air fitting installed in the top of the air helper spring. Push the airline tubing into the fitting as far as possible, *see Figure "A"*.

Select a location on the vehicle for the air inflation valves. The location can be on the bumper or the body of the vehicle, as long as it is in a protected location so the valve will not be damaged, but maintain accessibility for the air chuck, *see Figure "C"*. Drill a 5/16" hole and install the air inflation valve using two 5/16" flat washers per valve as supports, *see Figure "D"*. Run the airline tubing from the air helper spring to the valve, routing it to avoid direct heat from the engine, exhaust pipe, and away from sharp edges. Thermal sleeves have been provided for these conditions. The airline tubing should not be bent or curved sharply as it may buckle. Secure the airline tubing in place with the nylon ties provided. Push the end of the airline tubing into the inflation valve as illustrated, *see Figure "D"*.

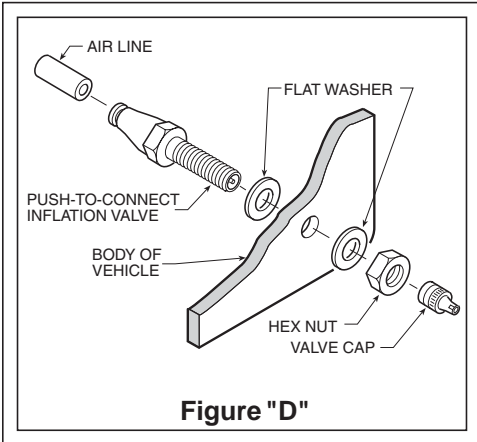

Figure "D"

STEP 6 - CHECK THE AIR SYSTEM

Once the inflation valves are installed, inflate the air helper springs to 70 psi and check the fittings for air leaks. Using a spray bottle, apply a solution of soap and water to the fittings. If a leak is detected at a airline tubing connection then check to make sure that the airline tube is cut as square as possible and that it is pushed completely into the fitting. The airline tubing can easily be removed from the fittings by exhausting all the pressure in the air springs and then pushing the collar towards the body of the fitting and then, with a pull, remove the airline tubing. Re-install the tubing and reinflate the air springs and check for leaks as noted above. If a leak is detected where the air fitting screws into the spring, just screw the air fitting into the air spring until the leak stops.

This now completes the installation. Install the wheels and torque the lug nuts to the manufacturer's specification. Lower the vehicle to the ground. Reattach the

negative battery cable and remove the wheel chocks from the front wheels. Before proceeding, check once again to be sure you have proper clearance around the air springs. With a load on your vehicle and the air helper springs inflated, you must have at least 1/2" clearance around the air springs. As a general rule, the air helper springs will support approximately 50 lbs. of load for each psi of inflation pressure (per pair). For example, 50 psi of inflation pressure will support a load of 2500 lbs. per pair of air helper springs. *FOR BEST RIDE* use only enough air pressure in the air helper springs to level the vehicle when viewed from the side (front to rear). This amount will vary depending on the load, location of load, condition of existing suspension and personal preference.

NOTE:

Too much air pressure in the air helper springs will result in a firmer ride, while too little air pressure will allow the air helper spring to bottom out over rough conditions. Too little air pressure will not provide the improvement in handling that is possible. ***TO PREVENT POSSIBLE DAMAGE MAINTAIN A MINIMUM OF 5 psi IN THE AIR HELPER SPRINGS AT ALL TIMES.***

NOTE:

Once the air helper springs are installed, it is recommended that the vehicle not be lifted by the frame, as over-extension may occur, resulting in damage to the air helper springs. However, should it become necessary to raise the vehicle by the frame, deflate both air helper springs completely.

