

AIR CONTROL ACCESSORY KIT

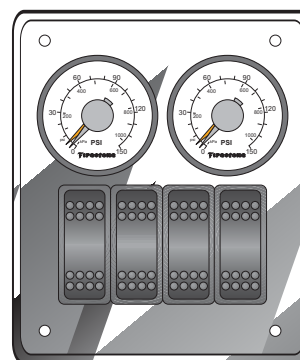

INSTALLATION INSTRUCTIONS

Congratulations on your purchase of a new Air Control Accessory Kit. This kit was designed to provide inflation control of your air springs. This kit will be an asset to your vehicle, meeting your air supply needs.

Please take a few minutes to read through the instructions, identify the components, and learn how to properly install your Air Control Accessory Kit.

NOTE:

The Air Control Accessory Kit can be used with most air spring products. If you are installing an air spring kit, do not install the air line tubing into the air springs as stated in the air spring manual.

NOTE ON CONNECTING THE AIR LINE TUBING

Cut the air line tubing as square as possible. To connect the air line tubing to the fittings, push the air line tubing into the fitting as far as possible. If for any reason the air line tubing must be removed, make sure the air springs are deflated, then push the collar of the fitting toward the body of the fitting and the air line tubing can be removed. To reassemble, make sure the air line tubing is cut square and push back into the fitting.

STEP 1 - PREPARE THE COMPONENTS

A) COMPRESSORS

Install the rubber isolators to the compressors in the holes located on the compressors feet. Insert the brass sleeve into the top of the rubber isolator, *see Figure "B"*. Install the threaded end of the T-fitting into the compressors head. Tighten the fitting sufficiently to engage the orange thread sealant. Next, install the pressure switch into the female end of the T-fitting, *see Figure "A"*.

PARTS LIST

COMPRESSORS	9210	2	3/8" -16 FLANGED NUT	8
SOLENOID BLOCK	9221	1	3/8" FLAT WASHER	8
AIR TANKS	9127	2	3/16" FLAT WASHER	18
DUAL AIR CONTROL PANEL S.S.		1	COMPRESSORST-FITTING	2
PRESSURE SWITCH 100-150	9193	2	PUSH-TO-CONNECT 1/4NPT X 3/8 STR	8
18 FT. 1/4" AIR LINE TUBING (BLACK)	9151	1	PUSH-TO-CONNECT 1/8NPTM TO 1/8 TUBE	4
40 FT. 1/8" AIR LINE TUBING (BLACK)	9222	1	LEVEL COMMAND TEMPLATE	1
30 FT. 3/8" AIR LINE TUBING (BLACK)	9223	3	NYLONTIE	30
ELECTRICAL ASSEMBLY	9224	1	15 FT. 16 GAUGE WIRE	1
10-32 x 1" MACHINE SCREW		12	MALE CONNECTOR 04X04	2
10-32 NYLON INSERT NUT		12	FUSE 20 AMP SPADE TYPE	2
10-32 X 1-3/4 S.H.C.S.		2	FUSE HOLDER SPADE TYPE	2
3/8" -16UNC X 1" HEX BOLT		8	MALE SPADE TERMINAL	2

B) AIR TANKS

Thread a 1/4" tube fitting and a 3/8" male push-to-connect tube fitting into either end of both air tanks, *see Figure "A"*. Tighten the fittings securely to engage the orange thread sealant.

STEP 2 - SELECT A MOUNTING LOCATION

A) COMPRESSORS ATTACHMENT

Begin by removing the positive battery cable. Select a convenient location to mount the compressors. This location should provide ample air flow and be protected from airborne debris and moisture. The mounting surface should be rigid to support the compressors, such as under the hood on a fender well or in a vented storage compartment. (*Note: The compressors can be mounted in any orientation.*)

Using the compressor template, mark and drill three 3/16" holes. Any burrs in the holes should be removed to prevent damage to the rubber isolators. Mount the compressors using the #10-32 x 1" machine screws, #10-32 lock nuts, and #10 washers supplied with the kit *see Figure "B"*. Maximum vibration isolation can be achieved by properly mounting the compressors. The machine screw and nut should be tightened only enough to bottom-out the brass insert *see Figure "B"*. **DO NOT OVER-TIGHTEN.** Over-tightening will crush the brass insert and the insulator, thereby reducing vibration isolation.

B) AIR TANK ATTACHMENT

Select a location to mount the air tanks. This should be in a protected location to prevent damage from rocks or airborne debris. Using the tank feet as a template, mark and drill 3/8" holes. Bolt the air tanks in place using the 3/8" -16 x 1" hex bolts with the 3/8" -16 flanged lock nuts and 3/8" washers provided. Ensure that the installation allows unrestricted access to the air ports on the tanks.

Figure "A"

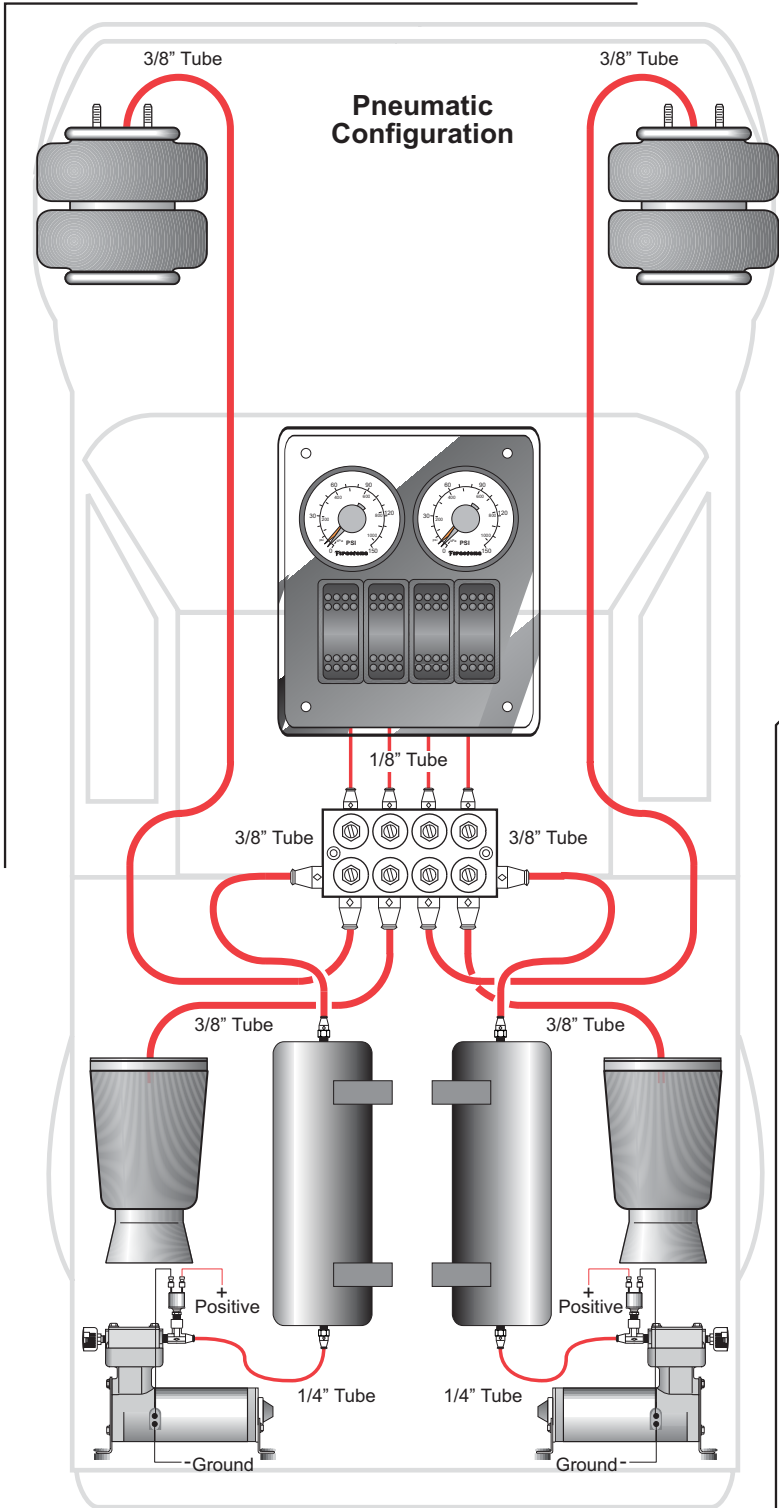

Please Note:
The Pneumatic Configuration displayed on this page is a general configuration for concept purposes only.

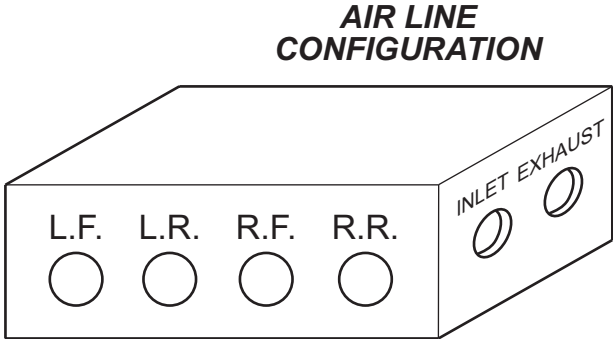
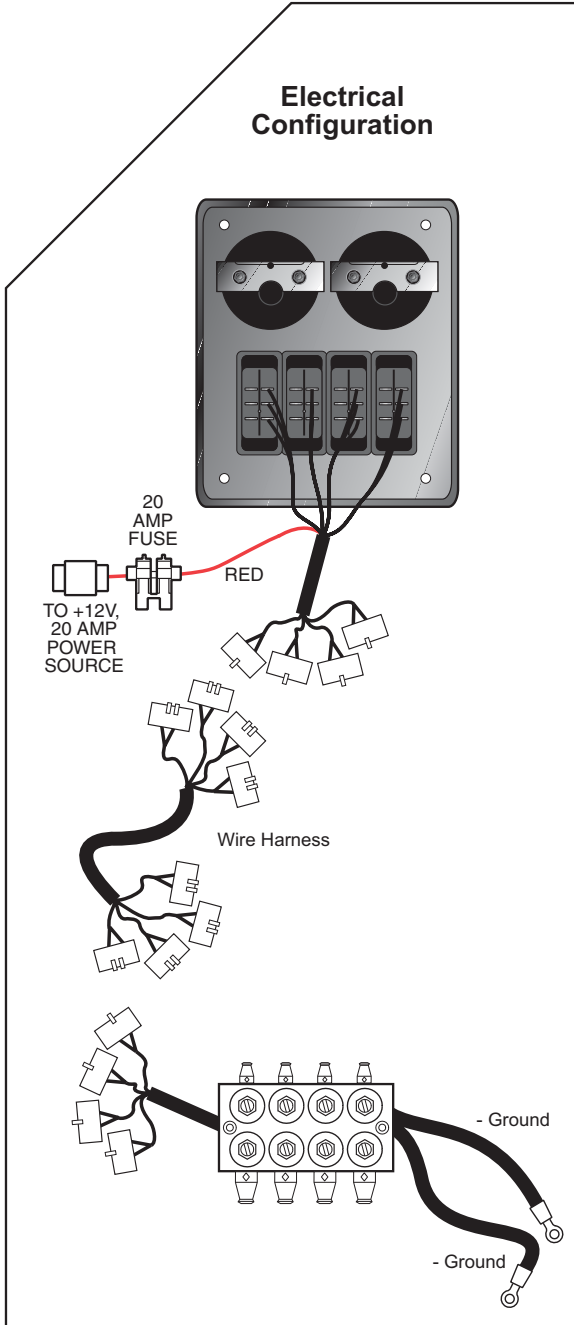

OUT TO AIR SPRINGS

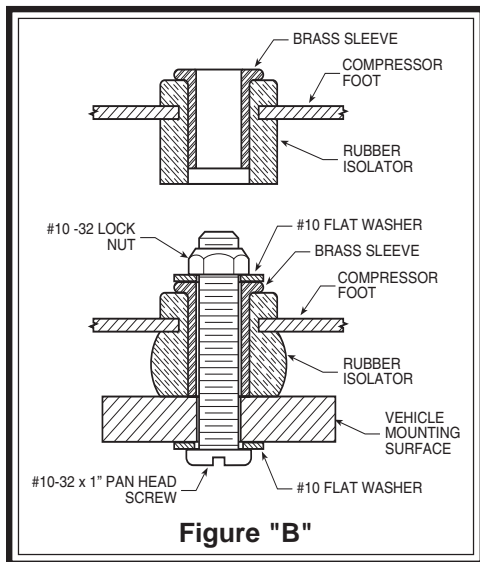

Figure "B"

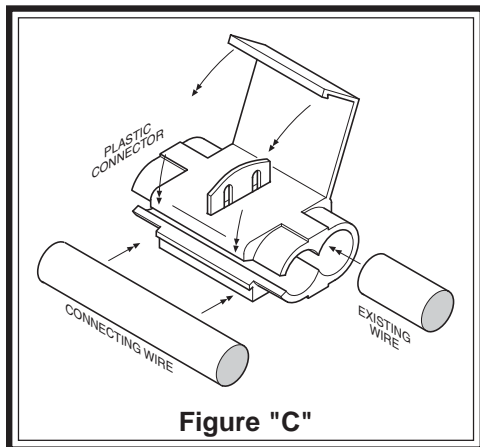

Figure "C"

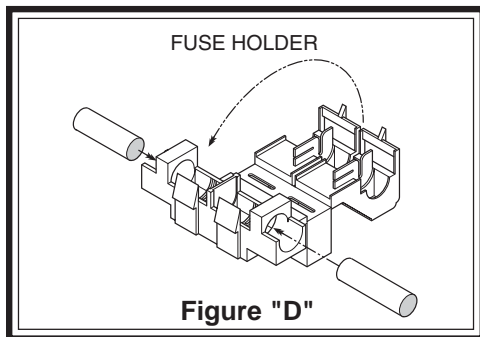

Figure "D"

C) GAUGE PANEL ATTACHMENT

Select a mounting surface for the gauge panel in the dashboard of your vehicle or other protected location. Using the gauge panel as a template, center mark the mounting holes on the dashboard. Drill a 3/16" hole on each center mark. **Do not attach the panel to the dashboard at this time.**

STEP 3 - PREPARE AND MOUNT THE SOLENOID BLOCK

Install four 1/8NPT fittings in one side of the solenoid block. Tighten the air fittings securely to engage the orange sealant. Install six 1/4 NPT 3/8 tube fittings in the other sides of the solenoid block as shown in Figure "A". Tighten the air fittings securely to engage the orange thread sealant.

Select a location to mount the solenoid block. This should be in a protected location to prevent damage from rocks or airborne debris. Using the solenoid block as a template, mark and drill two 3/16" holes. Mount solenoid block with 10-32 x 1-3/4" socket head cap screw and nylock nuts and washers.

STEP 4 - ROUTE THE ELECTRICAL HARNESS

All the wires are color coded to aid in installation of this kit.

Left Front	Blue wire
Left Rear	Green wire
Right Front	White wire
Right Rear	Yellow wire

Connect the wires from the solenoid block to the wiring harness by simply pushing the two pin connectors together until a clicking noise is heard. Then route the wiring harness to the control panel. Avoid routing the wiring harness next to direct heat from the engine, exhaust pipes and away from sharp edges. Then plug in each six pin connector to the back of the switches. You can choose which switch you would like to use on each air spring by the wire color codes.

STEP 5 - ROUTE THE AIR LINE TUBING

Please note: Do not fold or kink the air line tubing. A ragged or angled cut can cause a leak in the system. Push the air line tubing into the fitting as far as possible. Avoid routing the air line tubing next to direct heat from the engine or exhaust pipe, and away from sharp edges. The air line tubing should not be bent or curved sharply as it may buckle with age. Secure the air line tubing in place with the nylon ties provided.

Using the 1/4" air line tubing, measure the distance from the compressors to the air tanks. Cut the air line tubing accordingly, as squarely as possible. Push the air line tubing into the fittings as far as possible. Using the 1/8" air line tubing, measure the distance from the solenoid block to the control panel. Cut the air line tubing accordingly, as squarely as possible. The solenoid block is marked as to which air spring the gauge will read, see Figure "A". Using the 3/8" air line tubing, measure the distance from the solenoid block to each of the air springs. Cut the air line tubing accordingly, as squarely as possible. The solenoid block is marked as to which air spring each air line tubing goes to. Insert one end of the air line tubing into the fitting installed on the top of the air spring and insert the other end into the fitting in the solenoid block. Push the air line tubing into the fittings as far as possible.

STEP 6 - ROUTE THE ELECTRICAL WIRE (COMPRESSOR)

All necessary electrical wire and connectors have been included with this kit. Review the electrical schematic before beginning installation, see Figure "A".

Secure the ring terminal to a grounded component of the chassis. Route a length of wire from the pressure switch to a positive 12 volt, 20 amp, ignition activated power source on the vehicle. Cut a length of 16 gauge wire from the 15' supply included with this kit. Crimp a blue female terminal connector onto the lead from the compressor. Install the female terminal connector over the remaining spade on the pressure switch. Connect the lead from the pressure switch to the 12 volt wire with a wire connector. Slide the wire connector over the existing wire and insert the un-stripped lead from the pressure switch into the wire connector. Close the wire connector over both wires with pliers, see Figure "C".

Install the in-line fuse holder in the positive pressure switch lead. Cut the pressure switch lead near the wire connector and

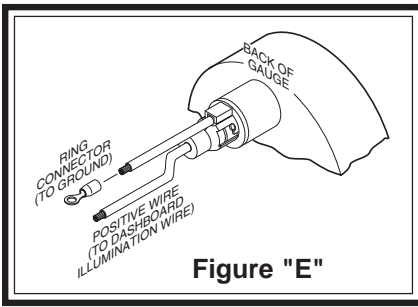

Figure "E"

insert the un-stripped ends of the wire into the fuse holder. Close the fuse holder over the wires with pliers and install the fuse, *see Figure "D"*.

STEP 7 - WIRE THE GAUGE PANEL FOR ILLUMINATION

There are two wires (one red and one black) attached to the gauge on the back of the control panel. Connect the red wire to a fused dashboard illumination wire. Connect the black wire to a suitable ground source, *see Figure "E"*.

Attach the end of the positive wire to a dashboard illumination wire using a wire connector. Slip the wire connector over the existing dashboard illumination wire and insert the un-stripped gauge panel wire into the wire connector. Close the wire connector onto the wires with pliers, *see Figure "C"*. Attach the black wire to a ground source by crimping a ring connector onto the wire and securing it to a suitable ground source on the vehicle. Note: Should additional wire be necessary to reach the dashboard illumination wire and ground source, use 18 gauge multi-strand wire.

STEP 8 - ATTACH THE GAUGE PANEL

Install the gauge panel on the dashboard where the holes were drilled in *Step 2C*. Attach the gauge panel to the dashboard or other mounting surface using the enclosed #10-32 x 1" machine screws, #10-32 lock nuts, and #10 washers.

STEP 9 - TEST THE SYSTEM

With the Air Control Accessory Kit and air springs installed, you are ready to test the system. Re-attach the positive battery cable. Turn on the ignition. The compressors will start and build pressure in the system. Push the paddle switch upward to inflate the air springs. The gauge will display how much air pressure is in the air springs. Inflate the air springs to 70 psi and check the fittings for air leaks with an applied solution of soap and water. If a leak is detected at a tubing connection, check to make sure that the tube is cut as square as possible and that it is pushed completely into the fitting. The tubing can easily be removed from the fitting by first releasing the pressure from the air spring, then by pushing the collar towards the body of the fitting and then pulling out the air line tubing.

SYSTEM OPERATION

The air control accessory kit allows the air springs to be inflated from the inside of the vehicle. Push the paddle switch up to inflate the air springs and down to deflate the air springs. This air accessory kit provides front-to-rear and side-to-side leveling.

FIRESTONE INDUSTRIAL PRODUCTS
12650 HAMILTON CROSSING BOULEVARD
CARMEL, IN 46032



TELEPHONE: 317-818-8600
1-800-247-4337
FAX: 317-818-8645

www.ride-rite.com