

DUAL AIR CONTROL

INSTALLATION INSTRUCTIONS

Congratulations on your purchase of a new Firestone Air Control Accessory Kit. This kit was designed to provide inflation control of your Firestone air helper springs. This kit will be an asset to your vehicle, meeting most all of your air supply needs.

Please take a few minutes to read through the instructions, identify the components, and learn how to properly install your Air Control Accessory Kit.

NOTE:

The Air Control Accessory kit can be used with all Firestone air helper springs products. If you are installing a Firestone suspension system do not install the air line tubing into the air springs as stated in the suspension system instruction manual. If you are adding the Air Control Accessory kit to an existing Firestone suspension system you will need to deflate the air springs and remove the air line tubing.

NOTE ON CONNECTING THE AIR LINE TUBING

Cut the air line tubing as squarely as possible. To connect the air line tubing to the fittings push the tubing into the fittings as far as possible. If for any reason the tubing must be removed the collar of the fitting can be pushed toward the body of the fitting and the tubing can be removed. Make sure the air helper springs are deflated. To reassemble make sure the tubing is cut squarely and push back into the fitting.

PARTS LIST

| | |
|---------------------------|---|
| DUAL AIR CONTROL PANEL | 1 |
| RELAY HARNESS 9307 | 1 |
| 10-32" X 1" MACHINE SCREW | 3 |
| 10-32" LOCKNUT | 3 |
| 3/16" WASHER | 6 |
| 1/8" NPT STRAIGHT FITTING | 1 |
| WIRE CONNECTOR | 2 |
| RING TERMINAL | 2 |

TOOLS REQUIRED

3/16" drill bit
3/8" drill bit
1/4" drill bit
Hand drill
Electrical pliers
Pliers
Phillips screw driver
Sharp knife
(2) 7/16" wrenches
Center punch

Air Line & Wiring Diagram

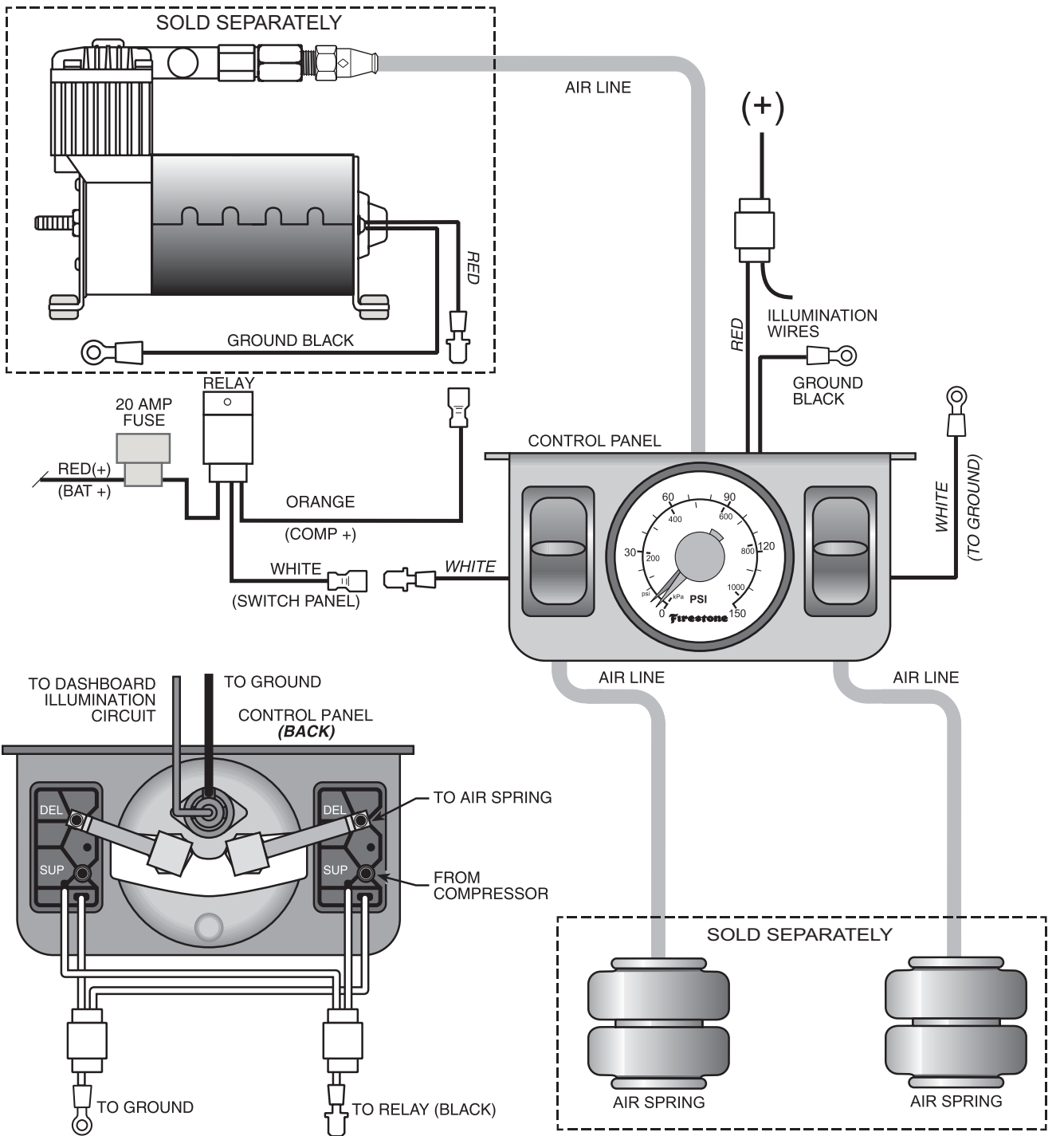

Connectors:





| | |
|---|---|
|  |  |
| Male spade connector | Female spade connector |
|  |  |
| Ring Terminal | Wire connector |

FIGURE "A"

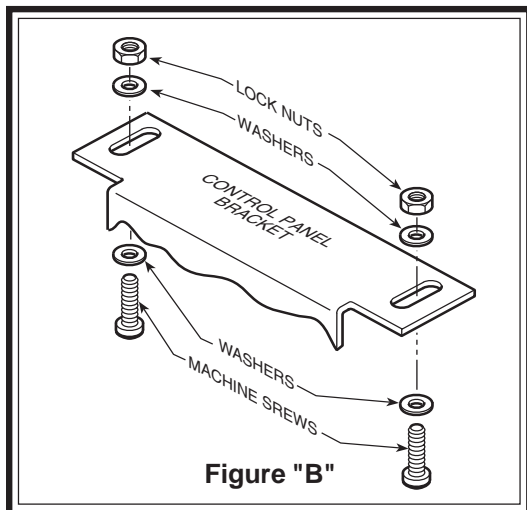

Figure "B"

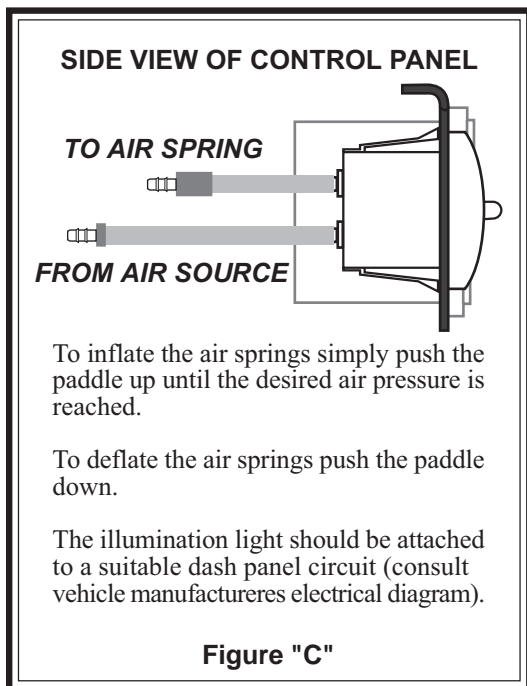

Figure "C"

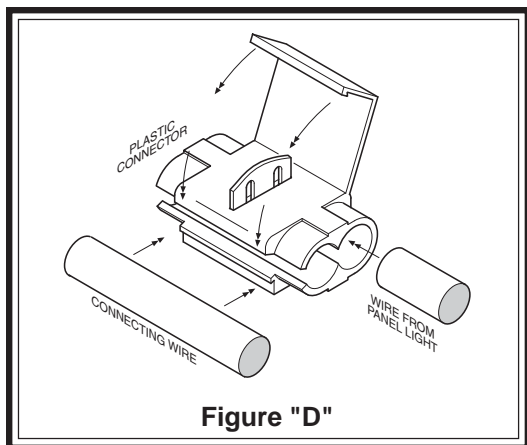

Figure "D"

STEP 1 LOCATING A MOUNTING AREA FOR THE GAUGE

Select a mounting surface under the dash of your vehicle or other protected location. Mark a 3/16" diameter hole at each of the mounting points, use the air control panel as a template for marking the holes. Drill two 3/16" diameter holes at each of the marked areas, refer to *Figure "B"*. **Do not attach the panel at this time.**

STEP 2 PREPARING THE DUAL AIR CONTROL PANEL

There are two wires one red and one black attached to the gauge on the back of the air control panel for illumination. Strip the black wire 1/4" leaving the wire exposed. Crimp the ring connector to the black wire, *see Figure "A"*. (Completion of the red wire connection in step 6)

STEP 3 CHECK FOR AIR IN THE SYSTEM

If there is no air pressure in the air springs please proceed with step 6. If there is air pressure in the air springs, both must be deflated. This is done by taking the valve core out of the external inflation valve(s) or use a tire gauge to remove the air from the air springs by depressing the valve stem.

STEP 4 ATTACHING THE AIR CONTROL PANEL TO THE DASH

Place the air control panel on the dash where the holes were drilled in *Step 1*. Using the machine screws and nuts provided in the kit attach the air control panel to the dash or other appropriate surface, *see Figure "B"*.

STEP 5 PREPARING AND ROUTING THE ELECTRICAL WIRE

Install the relay within three feet of the compressor. Nylon ties can be used to secure any excess wire and the relay neatly into place. Route the white wire labeled "Switch Panel" to the control panel. Connect the white wire to one of the white wires on the back of the switch. The remaining white wire will be grounded to the vehicle. Next, connect the orange wire labeled "Comp +" to the red (positive) wire on the compressor. Connect the red, fused wire labeled "Bat +" from the relay to the battery or another 12V (positive) source capable of supporting 20 amps. *See Figure "A"*.

STEP 6 WIRING THE AIR CONTROL PANEL FOR ILLUMINATION

Cut a piece of wire, it should reach a suitable fused dash panel circuit for illumination (positive). Consult the vehicle manufacturers electrical diagram. *See Figure "D"* for wiring and connector application. **NOTE:** Should additional wire be necessary, use 18 gage multistrand wire. Connect the black wire to a suitable ground.

YOU ARE NOW READY TO TEST THE SYSTEM

With the Ride-Rite air accessory kit and Firestone suspension products installed you are ready to test the system. Turn on the ignition. Push the paddle switch up, air pressure should read on the gauge showing how much air pressure is in the air springs. Each of the air line tubing connections can be inspected with a soap and water solution applied to the fittings were the air line enters the fitting. If a leak is detected the air line may not be pushed all the way in or cut squarely.

NOTE: The air control accessory kit is designed to monitor the air pressure in the air springs not the pressure between the air compressor and the gauge. If no air is reaching the air springs, the air line tubing

connections may be reversed. Please review these connections.

SYSTEM OPERATION

When the vehicle is loaded, the rear of the vehicle may drop several inches. The air control accessory kit allows the air springs to be inflated from inside the vehicle. Push the paddle up to inflate the air springs and push the paddle down to deflate the air springs.



www.riderite.com