

DUAL ELECTRIC AIR COMMAND II

INSTALLATION INSTRUCTIONS

Congratulations on your purchase of a new Dual Electric Air Command Kit. This kit was designed to provide inflation control of your air helper springs. This kit will be an asset to your vehicle, meeting nearly all of your air supply needs.

Please take a few minutes to read through the instructions, identify the components, and learn how to properly install your Dual Electric Air Command Kit.

NOTE:

The Dual Electric Air Command Kit can be used with all air helper spring products. If you are installing an air suspension system, do not install the air line tubing to the air springs as stated in the suspension system instruction manual. If you are adding the Dual Electric Air Command kit to an existing air suspension system, you will need to deflate the air springs and remove the air line tubing.

NOTE ON CONNECTING THE AIR LINE TUBING

Cut the air line tubing as squarely as possible. To connect the air line tubing to the fittings, push the tubing into the fitting as far as possible. If for any reason the tubing must be removed, release the air pressure from the air helper spring. Push the collar toward the body of the fitting and pull out the tubing. To reassemble, make sure the tubing is cut squarely and push the tubing back into the fitting.

TOOLS REQUIRED:

- **POWER DRILL**
- **3/16" DRILL BIT**
- **1/8" DRILL BIT**
- **CENTER PUNCH**
- **PHILLIPS SCREW DRIVER**
- **ELECTRICAL PLIERS**
- **PLIERS**
- **(2) 7/16" WRENCHES**
- **UTILITY KNIFE**

PARTS LIST

DUAL AIR CONTROL PANEL	2188	1	NYLON TIE	15
COMPRESSOR	9210	1	15 FT. 16 GAGE WIRE	1
1/8" NPT PUSH-TO-CONNECT STRAIGHT FITTING		1	FEMALE SPADE CONNECTOR	1
10 -32 x 1" MACHINE SCREW		3	MALE SPADE CONNECTOR	2
10 -32 LOCK NUT		3	RING TERMINAL	2
#10 FLAT WASHER		3	WIRE CONNECTOR	2
30 FT. AIR LINE TUBING		1	IN-LINE FUSE HOLDER	1
			20 AMP BLADE FUSE	1

2219 / 2256

Air Line & Wiring Diagram

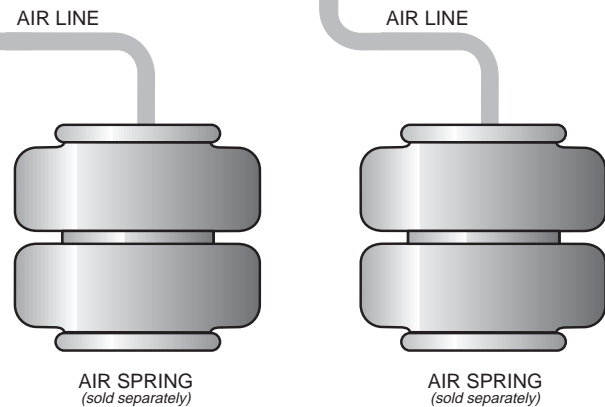
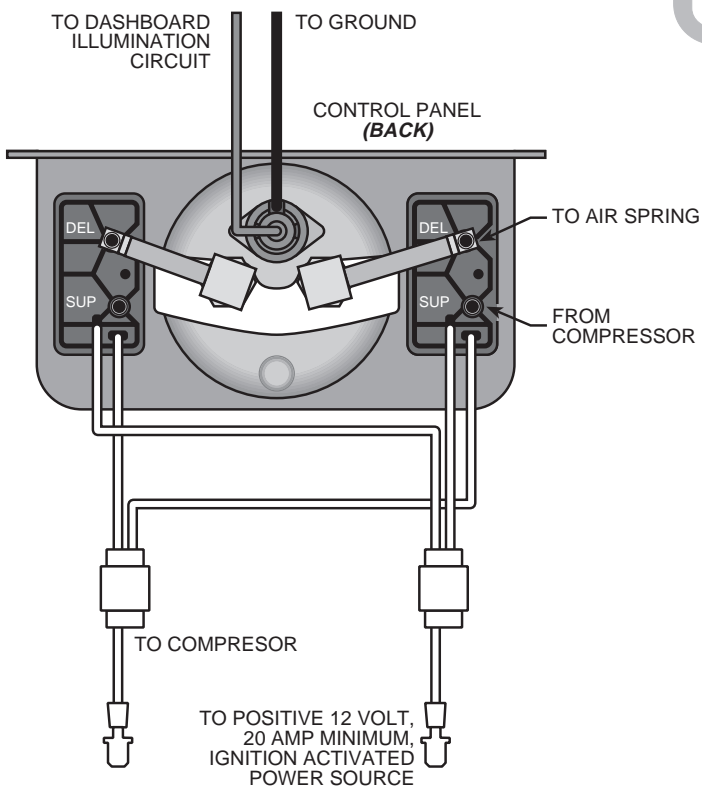
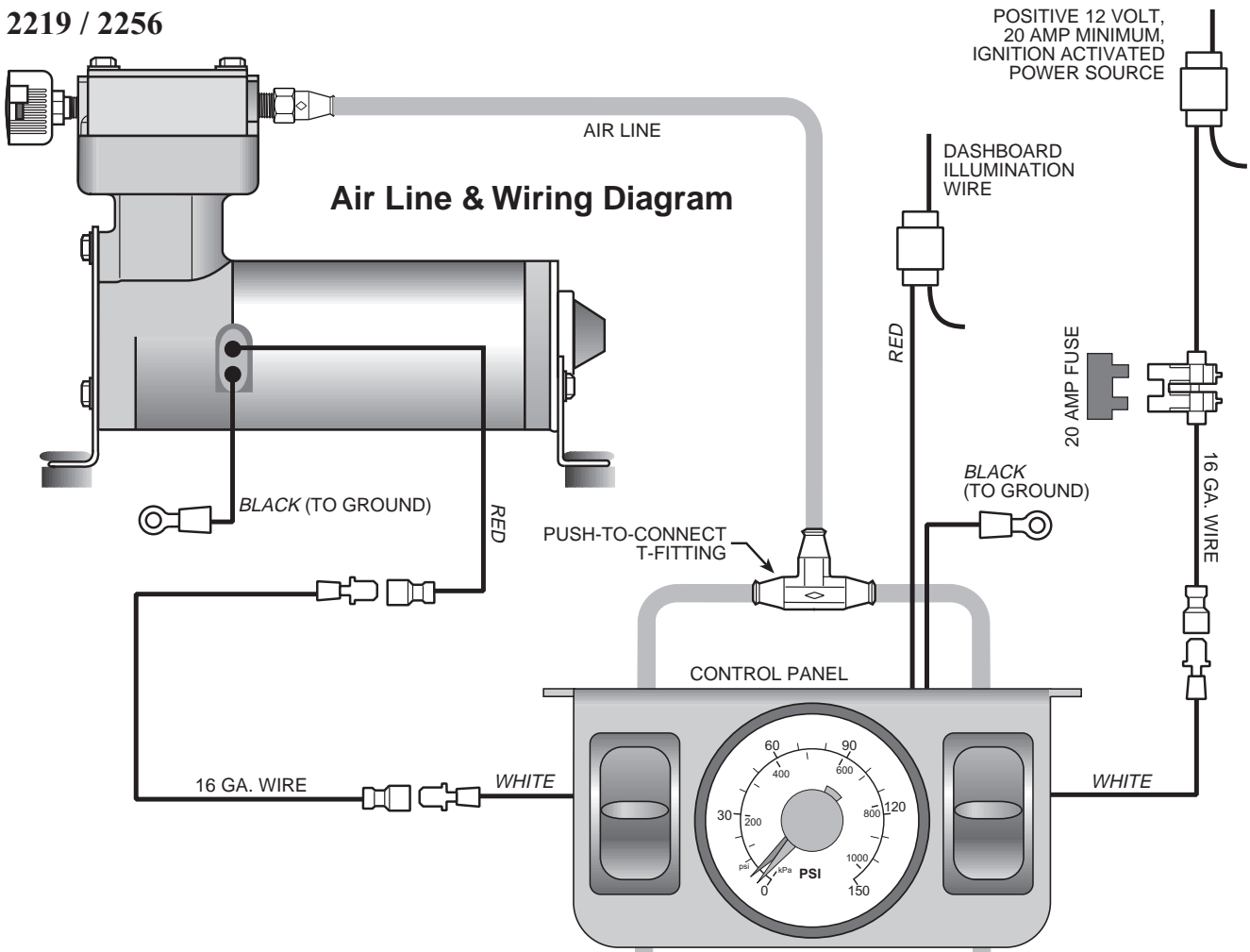

Connectors:





-  Male spade connector
-  Female spade connector
-  Ring Terminal
-  Wire connector
-  Inline fuse holder

FIGURE "A"

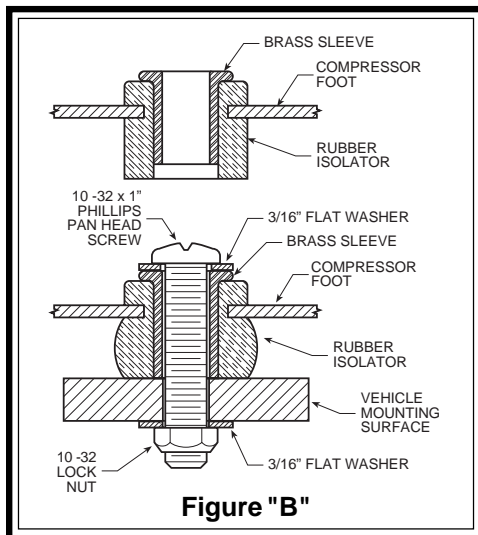

Figure "B"

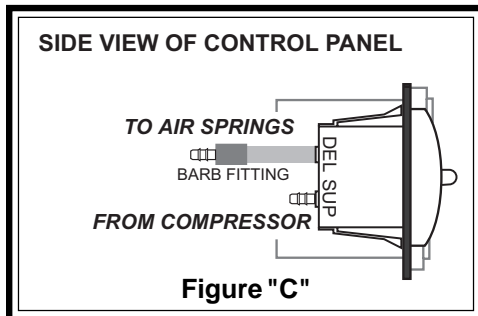

Figure "C"

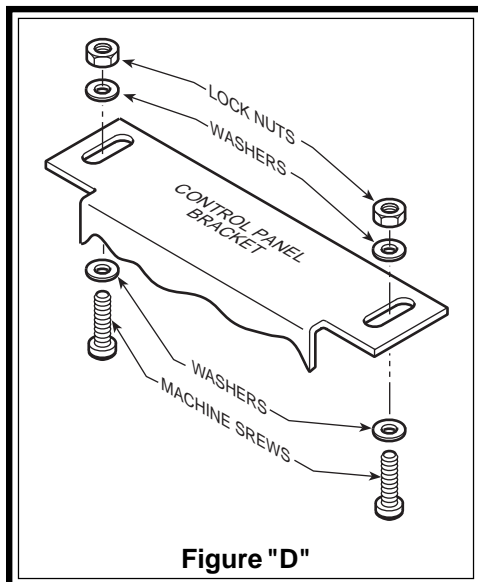

Figure "D"

STEP 1 - SELECT A MOUNTING LOCATION FOR THE CONTROL PANEL

Select a mounting location on the dashboard of your vehicle. This should be a protected location so that the control panel will not be damaged. To mount the gauge panel underneath the dashboard, use the control panel as a template and center-mark each mounting hole on the dashboard. Drill a 1/8" hole on each of the center-marks. *Do not attach the gauge panel to the dashboard at this time.*

STEP 2 - PREPARE THE COMPRESSOR

Install the 1/8" push-to-connect straight fitting into the head of the air compressor. Install the rubber isolators and brass sleeves into the compressor feet *see Figure "B"*.

STEP 3 - PREPARE THE CONTROL PANEL

Cut two pieces of air line tubing 3-1/2" in length, making the cut as square as possible. Before attaching the air line tubing to the barbed fitting on the gauge panel, soak the end of the tube (1") in hot water for a few minutes to soften the tubing. Install each length of tubing on to the barbed fittings on the back of the switches marked *SUP* (supply). Do not use pliers to work the tubing on to the barbed fitting, as the tubing may be damaged. Insert the remaining ends of the tubing into a push-to-connect T-fitting *see Figure "A"*.

STEP 4 - MOUNT THE COMPRESSOR

Begin by removing the negative battery cable. Select a convenient location to mount the compressor. This location should provide ample air flow and be protected from airborne debris and moisture. The mounting surface should be rigid to support the compressor, such as under the hood on a fender well or in a vented storage compartment.

Using the compressor as a template, mark and drill three 3/16" holes. Any burrs in the holes should be removed to prevent damage to the rubber isolators. Mount the compressor using the 10-32 x 1" machine screws, 10-32 lock nuts, and 3/16" washers supplied with the kit *see Figure "B"*. Maximum vibration isolation can be achieved by properly mounting the compressor. The machine screw and nut should be tightened only enough to bottom-out the brass insert *see Figure "B"*. **DO NOT OVER-TIGHTEN.** Over-tightening will crush the brass insert and the insulator, thereby reducing vibration isolation.

Attach the ring connector on the black compressor wire to a grounded component of the vehicle chassis.

STEP 5 - ROUTE THE AIR LINE TUBING

Before installing the air line tubing, ensure that there is no pressure in the air springs. To release the air pressure from the air springs, remove the valve core from the manual inflation valves or release the pressure by using a tire gauge to depress the valve stem.

A) COMPRESSOR TO CONTROL PANEL

Cut a piece of air line tubing that will reach from the control panel to the compressor. Cut the air line tubing as squarely as possible and insert the tubing into the push-to-connect straight fitting on the compressor. Insert the other end into the T-fitting on the control panel as far as possible *see Figures "A" & "C"*. *Do not fold or kink the tubing.* It may be necessary to drill a hole in the firewall to route the tubing. Ensure that the tubing is protected from sharp edges when passing through the firewall. A rubber grommet may be installed in the hole drilled in the firewall to protect the tubing from chafing.

B) CONTROL PANEL TO AIR SPRINGS

Cut two lengths of air line tubing. Each length must reach from the control panel to each air spring. Before attaching the air line tubing to the barbed fitting on the gauge panel, soak the end of the tube (1") in hot water for a few minutes to soften the tubing. Slide the tubing as far as possible onto the barbed fitting marked *DEL* (delivery) on the back of the paddle switch *see Figures "A" & "C"*. Install the opposite end of the tubing into the push-to-connect air fitting on each air spring. *Route the air line so that the left paddle switch inflates the left air spring and the right paddle switch inflates the right air spring.* Make sure that the tubing is protected from sharp edges when passing through the firewall. A rubber grommet may be installed in the hole drilled in the firewall to protect the tubing from chafing.

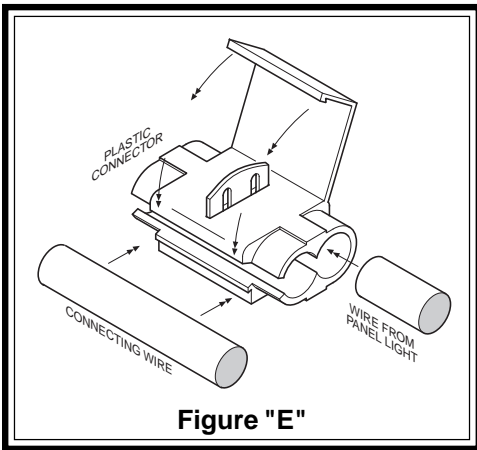

Figure "E"

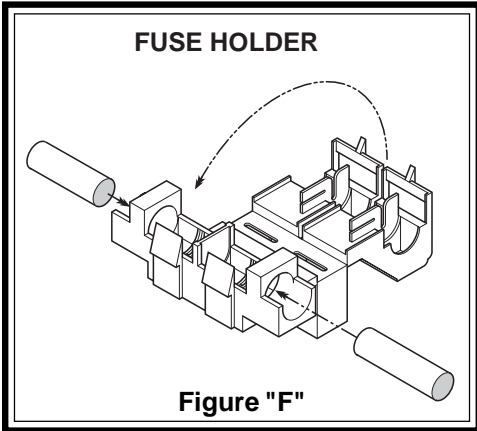

Figure "F"

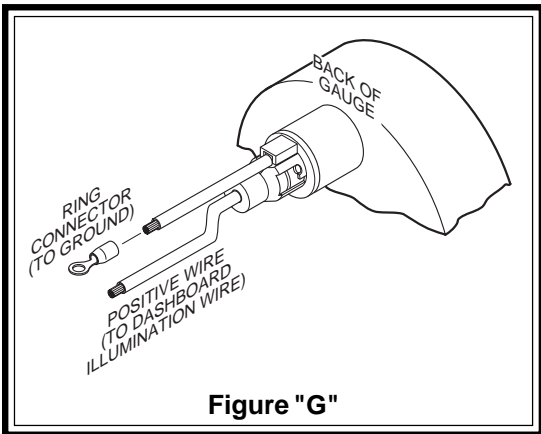

Figure "G"

STEP 6 - ATTACH THE CONTROL PANEL

Place the control panel on the dashboard where the mounting holes were drilled in *Step 1*. Use the provided screws to attach the control panel to the dashboard *see Figure "D"*.

STEP 7 - ROUTE THE ELECTRICAL WIRE

All necessary 16 gage electrical wire and connectors are enclosed with the kit. Review the electrical schematic before beginning installation *see Figure "A"*.

Cut a length of 16 gage wire that will reach from the red wire on the compressor to either white wire on the control panel. Strip 1/4" off each end of the 16 gage wire and crimp a male spade connector onto one end and a female spade connector on to the opposite end. Attach the 16 gage wire to the red compressor wire by pushing the female and male spade connectors together. Attach the other end of the wire to *either* white wire on the control panel.

Cut another length of 16 gage wire that will reach from the control panel to a positive 12 Volt, 20 Amp minimum, ignition activated power source. Strip 1/4" off one end of the 16 gage length and crimp a female spade connector onto the wire. Attach the wire to the remaining white wire on the control panel by pushing the male and female spade connectors together. Attach the wire from the air control panel to the power source with the supplied wire connector. Slide the wire connector over the existing power wire, then slide the un-stripped compressor wire into the wire connector. Close the wire connector over both wires with pliers *see Figure "E"*. Next, install the in-line fuse holder. Cut the compressor wire near the power source. Insert the un-stripped ends of the wires into the fuse holder. Use pliers to close the fuse holder over the wires and insert the 20 Amp blade fuse *see Figure "F"*.

STEP 8 - WIRE THE CONTROL PANEL FOR ILLUMINATION

There are two wires (one red and one black) attached to the gauge on the back of the control panel. Connect the red wire to a fused dashboard illumination wire. Connect the black wire to a suitable ground source *see Figure "G"*.

Attach the end of the positive wire to a dashboard illumination wire using a wire connector. Slip the wire connector over the existing dashboard illumination wire and insert the un-stripped gauge panel wire into the wire connector. Close the wire connector over the wires with pliers *see Figure "E"*. Attach the black wire to a ground source by crimping a ring connector on to the wire and securing it to a suitable ground source on the vehicle. *Note:* Should additional wire be necessary to reach the dashboard illumination wire and ground source, use 16 gage multi-strand wire.

STEP 9 - CHECK THE SYSTEM

With the Dual Electric Air Command Kit and your air helper springs installed, you are ready to test the system. Reattach the negative battery cable. Turn on the vehicle's ignition. Push the paddle switch up to inflate the air springs. The gauge will display how much air pressure is in each air spring. Inflate the air helper springs to 70 psi and check the fittings for air leaks with an applied solution of soap and water. If a leak is detected at a tubing connection, check to make sure that the tube is cut as square as possible and that it is pushed completely into the fitting. The tubing can easily be removed from the fitting. First, release the pressure from the air spring. Push the collar towards the body of the fitting and pull out the tube.

SYSTEM OPERATION

The Dual Electric Air Command Kit allows the air springs to be inflated from the inside of the vehicle. Push the paddle switch up to inflate the air springs and push the paddle switch down to deflate the air springs. Each air spring can be controlled individually with the corresponding paddle switch.