

INSTALLATION INSTRUCTIONS

Congratulations - your new Air Helper Springs are quality products capable of improving the handling and comfort of your vehicle. As with all products, proper installation is the key to obtaining all of the benefits your kit is capable of delivering. Please take a few minutes to read through the instructions to identify the components and learn where and how they are used. It is a good idea to start by comparing the parts in your kit with the parts list below.

The heart of the air spring kit is, of course, the air helper springs. Remember that the air helper springs must flex and expand during operation, so be sure that there is enough clearance to do so without rubbing against any other part of the vehicle.

Be sure to take all applicable safety precautions during the installation of the kit. The instructions listed in this brochure and the illustrations all show the left, or driver's side of the vehicle. To install the right side assembly simply follow the same procedures.

WARNING:

Do not inflate this assembly when it is unrestricted. The assembly must be restricted by the suspension or other adequate structure. Do not inflate beyond 100 psi. Improper use or over inflation may cause property damage or severe personal injury.

This kit includes inflation valves and air lines for each air spring. This will allow you to compensate for unbalanced loads. If you would rather have a single inflation valve system to provide equal pressure to both air springs, your dealer can supply the optional "T" fitting.

IMPORTANT!

For your safety and to prevent possible damage to your vehicle, do not exceed the maximum load recommended by the vehicle manufacturer (GVWR). Although your Air Helper Springs are rated at a maximum inflation pressure of 100 psi, this pressure may allow you to carry too great a load on some vehicles. It is best to have your vehicle weighed once it is completely loaded and compare that weight to the maximum allowed. Check your vehicle owner's manual or data plate on driver side door for maximum loads listed for your vehicle.

When inflating your Air Helper Springs, add air pressure in small quantities, checking pressure frequently during inflation. The air spring requires much less air volume than a tire and, therefore, inflates much quicker.

PARTS LIST

AIR SPRING	6781	2	3/8"-16 X 1-1/2" HEX BOLT	4
LEFT UPPER BRACKET	5149	1	3/8"-16 X 1" HEX BOLT	4
RIGHT UPPER BRACKET	5148	1	3/8"-16 FLANGE NUT	16
LOWER BRACKET	5150	2	3/8"-16 X 3/4" FLANGE BOLT	2
FRAME CLIP	5151	2	3/8"-16 X 5 1/2" CARRIAGE BOLT	4
BRACKET STRAP	5086	4	3/8" FLAT WASHER	4
18 ft. TUBING	0938	1	5/16" FLAT WASHER	4
INFLATION VALVE	3032	2	THERMAL SLEEVE	4
PUSH-TO-CONNECT ELBOW	3031	2	NYLON TIE WRAP	6

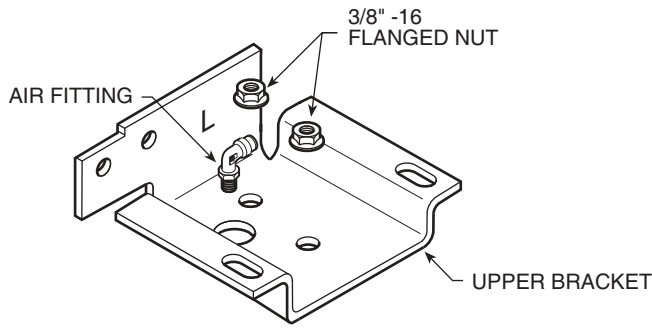

NOTE: Both illustrations are of the left, or driver's side of the vehicle. Reverse any orientations when assembling and installing the right, or passenger's side of the vehicle.

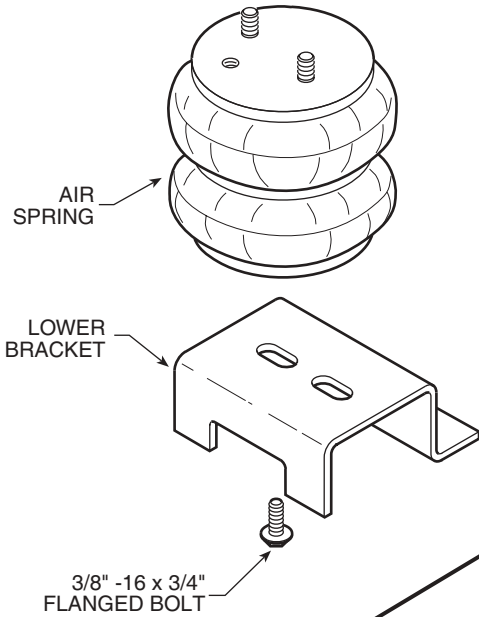

KIT TO FRAME ASSEMBLY

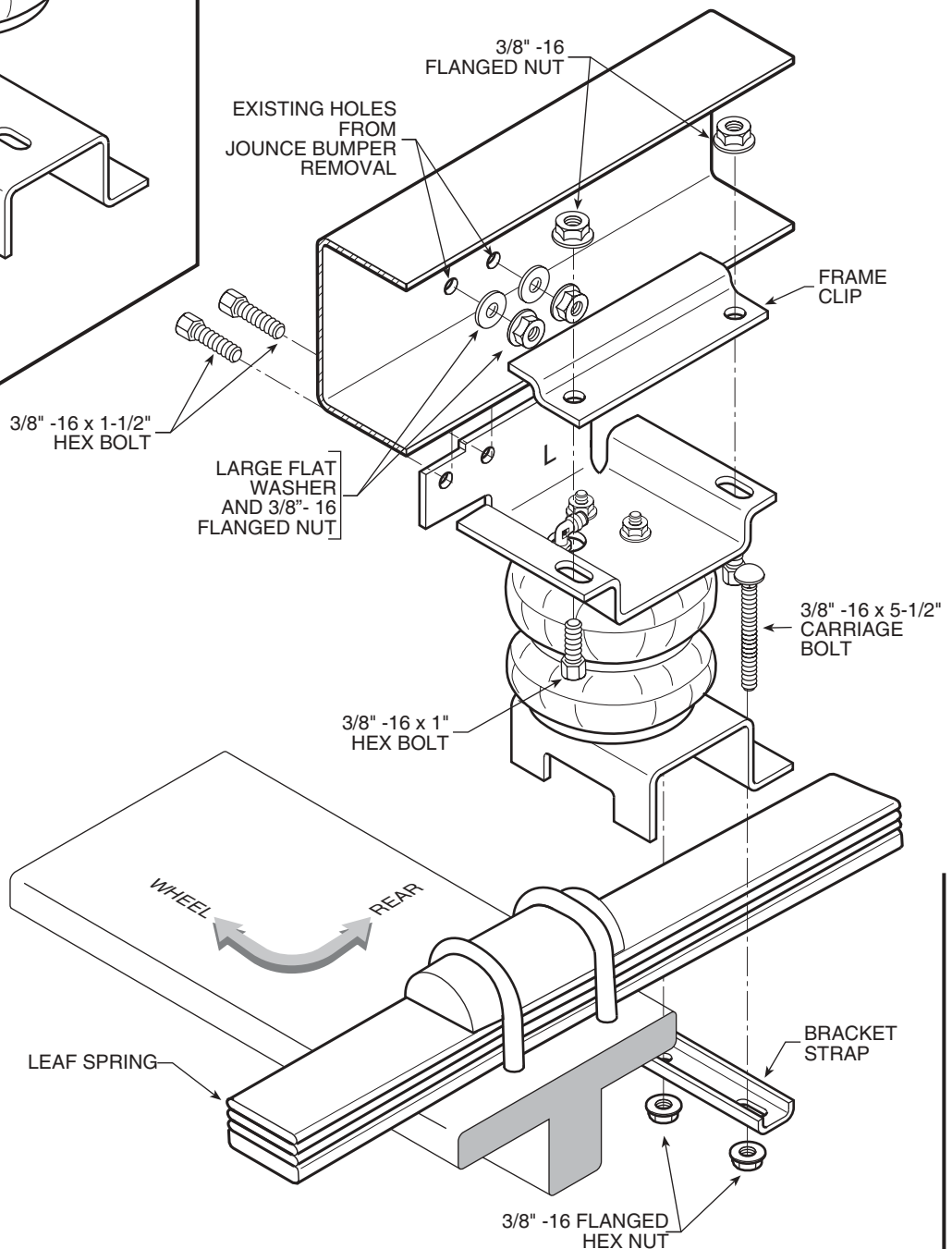

FIGURE "A"

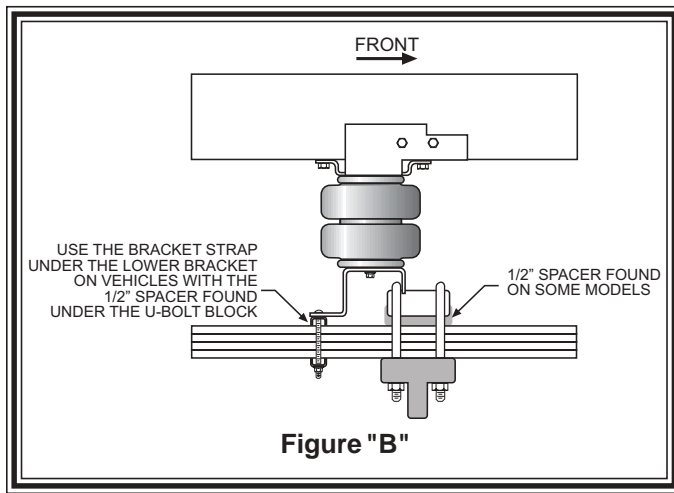

Figure "B"

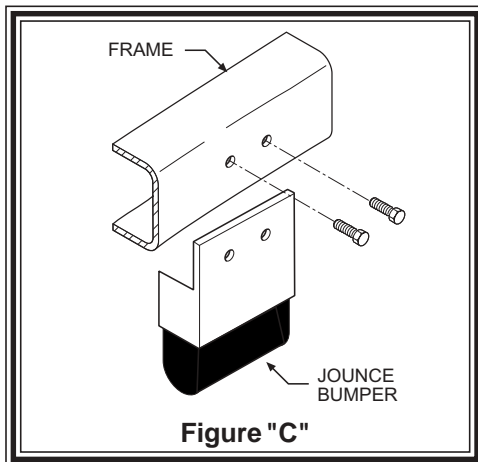

Figure "C"

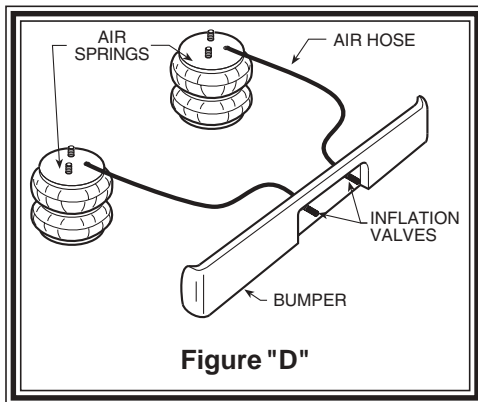

Figure "D"

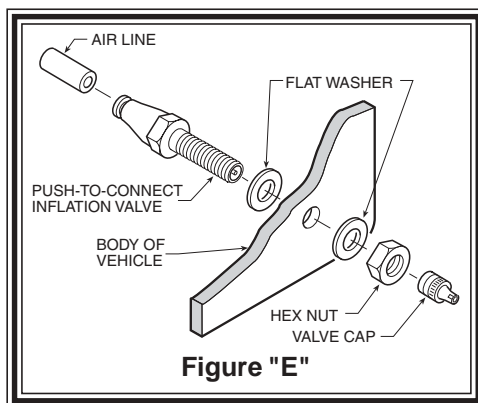

Figure "E"

NOTE:

Please read through this manual completely before installing the air spring kit to your vehicle.

STEP 1 - PREPARE THE VEHICLE

With the vehicle on a solid, level surface chock the front wheels. Remove the negative battery cable.

STEP 2 - PRE-ASSEMBLE THE KIT

Pre-assembly will begin with the left (driver's) side of the vehicle. Select one air helper spring and the left upper bracket from your kit. Insert the studs on the air spring in the mounting holes in the upper bracket. Make sure that the air inlet hole on the air spring is visible through the access hole in the upper bracket. Fasten the upper bracket to the air spring by installing

two 3/8"-16 flanged hex nuts on the air spring's studs. Next, install the air fitting into the air spring through the access hole in the upper bracket. Tighten the air fitting so as to make contact with the nylon ring and then tighten 1/2 turn to snug the fitting. No thread sealant is needed. Select one lower bracket from your kit. Fasten the air spring to the lower bracket using a 3/8"-16 flanged hex bolt in the hole in the lower bracket, *see Figures "A" & "B"*.

STEP 3 - INSTALLING THE ASSEMBLY TO THE VEHICLE

Some Spartan chassis come with a 1/2" spacer plate located between the leaf stack and the leaf spring retainer block (see **Figure "B"**). If your vehicle is so equipped, you will need to place a bracket strap under the lower bracket, as shown in **Figure "B"**, to keep the assembly level.

Secure the upper bracket to the frame rail where the jounce bumper was removed (**Figure "C"**) using the 3/8"-16 X 1-1/2" hex head bolts, 3/8" flat washers, and 3/8"-16 flange nut, *see Figure "A"*. Place the frame clip on the frame rail and attach it to the upper bracket using the 3/8"-16 X 1" hex head bolts and 3/8"-16 flange nut, *see Figure "A"*. Next, insert the 3/8"-16 x 5 1/2" carriage bolts through the square holes in the lower bracket. The lower bracket should be aligned over the leaf spring while capturing the leaf spring U-bolt on the front, *see Figure "B"*. The carriage bolts should be straddling the leaf stack. Slide the bracket strap on the carriage bolts and secure it with two 3/8"-16 flanged lock nuts, *see Figure "A"*. Once the assembly is in place, ensure that there is at least 1/2" of clearance around the air spring.

STEP 4 - INSTALLATION OF THE PASSENGER'S SIDE ASSEMBLY

Follow steps 1-3 with reverse orientations for assembly and installation of the passenger's side assembly.

STEP 5 - INSTALL THE AIR LINE AND INFLATION VALVE

Uncoil the airline tubing and cut it into two equal lengths. *DO NOT FOLD OR KINK THE AIRLINE TUBING*. Try to make the cut as square as possible. Insert one end of the airline tubing into the air fitting installed in the top of the air helper spring. Push the airline tubing into the fitting as far as possible *see Figure "A"*.

Select a location on the vehicle for the air inflation valves. The location can be on the bumper or the body of the vehicle, as long as it is in a protected location so the valve will not be damaged, but maintain accessibility for the air chuck *see Figure "D"*. Drill a 5/16" hole and install the air inflation valve using two 5/16" flat washers per valve as supports *see Figure "E"*. Run the airline tubing from the air helper spring to the valve, routing it to avoid direct heat from the engine, exhaust pipe, and away from sharp edges. Thermal sleeves have been provided for these conditions. The airline tubing should not be bent or curved sharply as it may buckle. Secure the airline tubing in place with the nylon ties provided. Push the end of the airline tubing into the inflation valve as illustrated in **Figure "E"**.

STEP 6 - CHECK THE AIR SYSTEM

Once the inflation valves are installed, inflate the air helper springs to *70 psi* and check the fittings for air leaks. Using a spray bottle, apply a solution of soap and water to the fittings. If a leak is detected at a airline tubing connection then check to make sure that the airline tube is cut as square as possible and that it is pushed completely into the fitting. The airline tubing can easily be removed from the fittings by exhausting all the pressure in the air springs and then pushing the collar towards the body of the fitting and then, with a gentle pull, remove the airline tubing. If a leak is detected where the air fitting screws into the spring, screw the air fitting into the air spring until the leak stops. Reinflate the air springs and check for leaks as noted above.

This now completes the installation. Install the wheels and torque the lug nuts to the manufacturer's specification. Raise the vehicle by the axle and remove the jack stands. Lower the vehicle to the ground. Reattach the negative battery cable and remove the wheel chocks from the front wheels. Before proceeding, check once again to be sure you have proper clearance around the air springs. With a load on your vehicle and the air helper springs inflated, you must have at least *1/2"* clearance around the air springs. As a general rule, the air helper springs will support approximately 50 lbs. of load for each psi of inflation pressure (per pair). For example, 50 psi of inflation pressure will support a load of 2500 lbs. per pair of air helper springs. *FOR BEST RIDE* use only enough air pressure in the air helper springs to level the vehicle when viewed from the side (front to rear). This amount will vary depending on the load, location of load, condition of existing suspension and personal preference.

NOTE:

Too much air pressure in the air helper springs will result in a firmer ride, while too little air pressure will allow the air helper spring to bottom out over rough conditions. Too little air pressure will not provide the improvement in handling that is possible. ***TO PREVENT POSSIBLE DAMAGE MAINTAIN A MINIMUM OF 5 psi IN THE AIR HELPER SPRINGS AT ALL TIMES.***

NOTE:

Once the air helper springs are installed, it is recommended that the vehicle not be lifted by the frame, as over-extension may occur, resulting in damage to the air helper springs. However, should it become necessary to raise the vehicle by the frame, deflate both air helper springs completely.

