



Unit 626 Kilshane Avenue, North West Business Park, Ballycoolin, Dublin 15, Ireland  
 Telephone: +353 1 8612 632, Fax: +353 1 8612 647, email: sales@driveriteltd.com

## W21-760-2101

### INSTALLATION INSTRUCTIONS

All work should be carried out in a properly equipped workshop with due regard to Health and Safety Regulations. No further reference to Health and Safety Regulations will be made, but they must be considered at all times.

The kit should be opened and the contents checked against the parts list provided.

Identify the various components and familiarise yourself with them using drawings and information provided.

#### **WARNING**

*Do not inflate this assembly when it is unrestricted. When installed, a minimum of 10 psi should be maintained in the air bellows at all times to avoid damage. Do not inflate beyond 100 psi.*

#### **IMPORTANT**

*This kit is not designed to increase the GVW of your vehicle. For your safety and to prevent possible damage to your vehicle, do not exceed the maximum load recommended by the vehicle manufacturer.*

#### **PARTS LIST**

255C 1.5 AIR SPRING	6957	2	3/8" LARGE FLAT WASHER	4
UPPER BRACKET (RIGHT)	5157	1	1/4" LOCK WASHER	2
UPPER BRACKET (LEFT)	5158	1	1/4" HEX NUT	2
LOWER BRACKET	5159	2	PUSH-TO-CONNECT	
AXLE STRAP	1163	2	MALE AIR FITTING	3046
HEAT SHIELD	1004	1	PUSH-TO-CONNECT	
3/8" -16 x 1" HEX BOLT		4	INFLATION VALVE	3032
3/8" -16" x 3" CARRIAGE BOLT		4	5/16" FLAT WASHER	4
3/8" -16 FLANGED LOCK NUT		12	AIR LINE TUBING	1
3/8" -16 x 3/4" HEX BOLT		2	NYLON TIE	6
1/4" -20 x 1" HEX BOLT		2	THERMAL SLEEVE	2
1/4" FLAT WASHER		4		

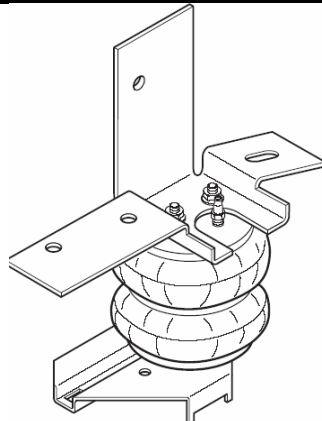

**FIGURE "A"**

**NOTE:** Both illustrations are of the left, or drivers side, of the vehicle. Reverse any orientations when assembling and installing the right, or passenger, side of the vehicle.

**KIT ASSEMBLY**

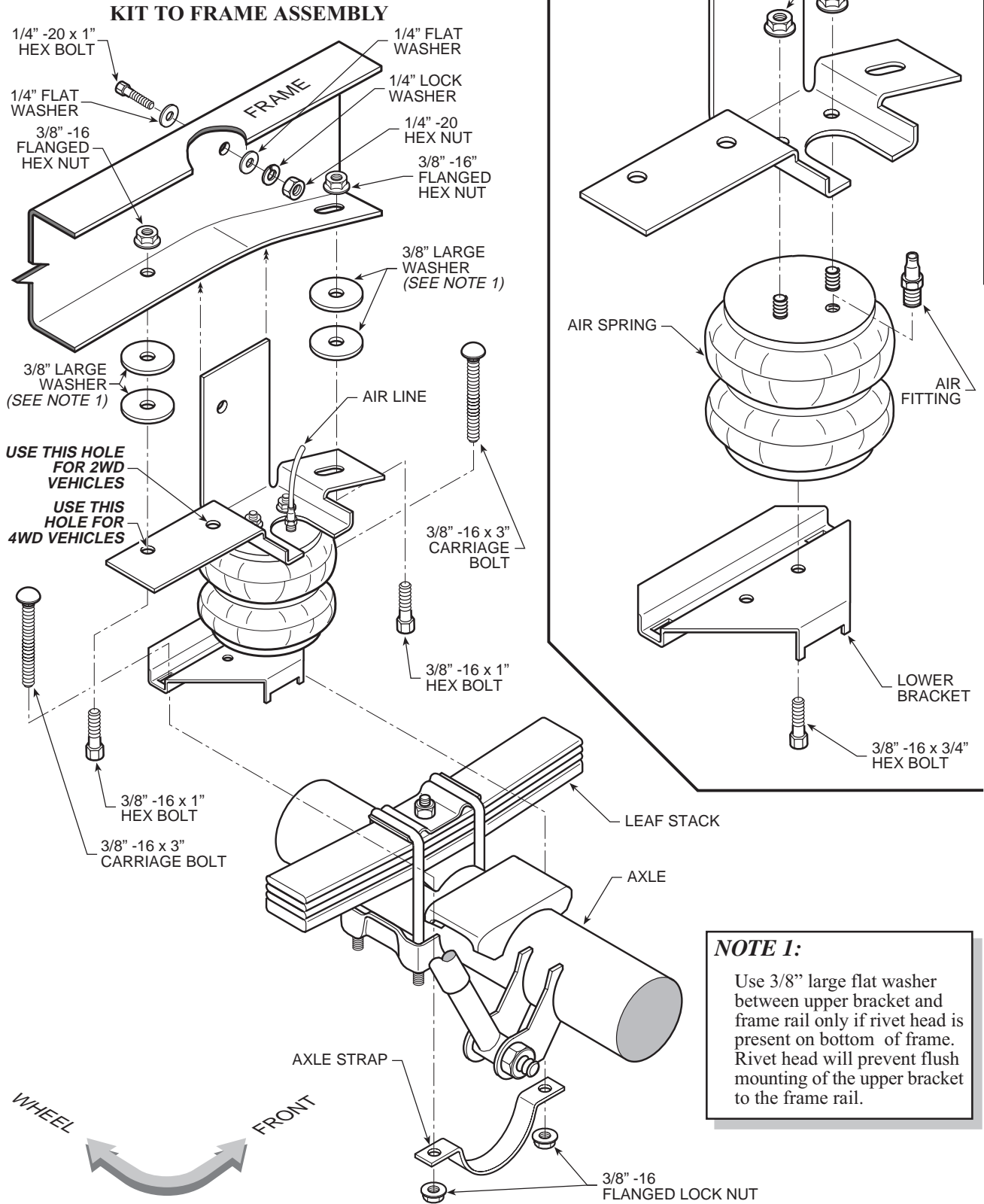

**NOTE 1:**  
 Use 3/8" large flat washer between upper bracket and frame rail only if rivet head is present on bottom of frame. Rivet head will prevent flush mounting of the upper bracket to the frame rail.

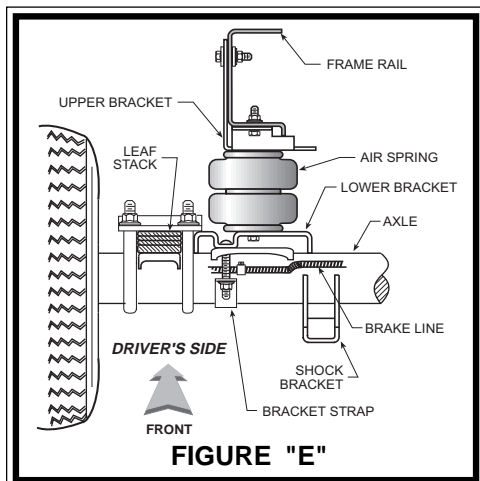
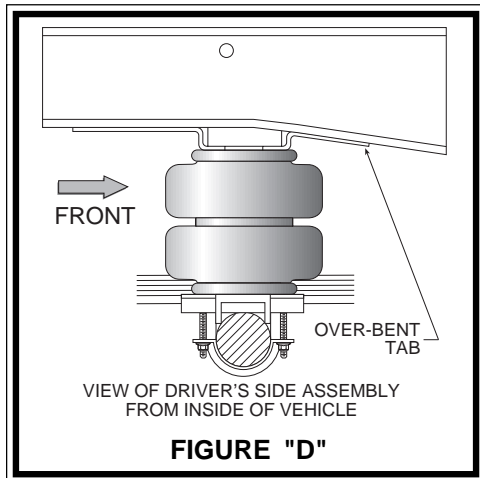
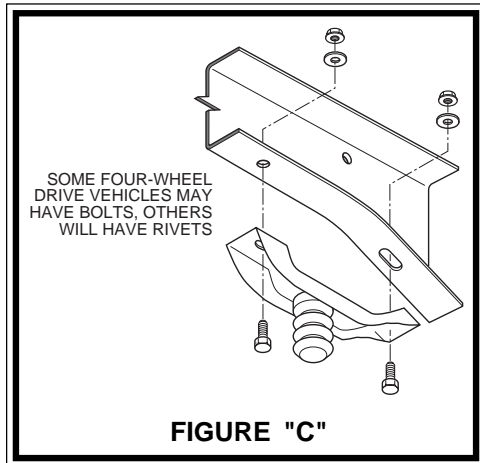
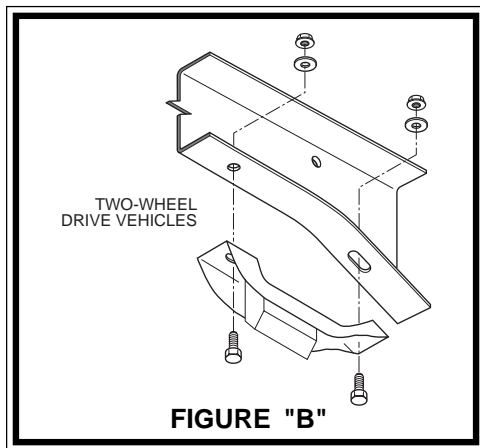

## STEP 1 - PREPARE THE VEHICLE

Remove the positive battery cable. With the vehicle on a solid, level surface chock the front wheels. Raise the vehicle by the axle and remove the rear wheels. After the removal of the wheels lower the vehicle so the axle rests on jack stands rated for your vehicles weight.

*This installation assumes that there is no load in the truck.*

### NOTE:

This kit is designed to fit both two-wheel and four-wheel drive vehicles. The jounce bumper and brackets must be removed for installation of this kit. The jounce bumper and bracket on the two-wheel drive can be unbolted and removed *see Figure "B"*. The jounce bumper and bracket on the four-wheel drive may be bolted or riveted in place, depending on model year. Simply unbolt the jounce bumper bracket and remove from the frame *see Figure "C"*. On older models, remove the jounce bumper by drilling out two rivets that fasten the bracket to the frame. Complete the removal by cutting off the heads with a cold chisel. The completion of the kit installation is the same for the two-wheel and four-wheel drive.

## STEP 2 - PRE-ASSEMBLE THE KIT

This kit is supplied with a right and left upper bracket. Begin by installing the left (driver's side) upper bracket. This bracket will have the "over-bent tab" *see Figure "D"*. The lower bracket is the same for both sides. Align the studs on the top of one of the air springs with the mounting holes in the upper bracket while ensuring that the air hole is visible through the slot in the upper bracket. Insert the studs into the holes and secure the air spring to the upper bracket with 3/8" -16 flanged lock nuts *see Figure "A"*. Next, install the male push-to-connect air fitting in the air inflation hole. Tighten the air fitting securely to engage the orange thread sealant.

To attach the lower bracket to the air spring, first position the bracket on the axle housing over the jounce pad *see Figures "A" & "E"*. Position the bracket so that the narrow end is toward the center of the vehicle. The air spring must be secured to the lower bracket through the forward hole. Once the correct mounting hole for the lower bracket has been identified, remove the bracket from the axle and fasten to the air spring using a 3/8" -16 x 3/4" hex bolt (*finger tight*). *Note that this bolt will be tightened in Step 3.*

## STEP 3 - INSTALL THE ASSEMBLY TO THE VEHICLE

Set the assembly in place on the axle housing over the jounce pad. The lower bracket should butt against the U-bolts on the leaf spring *see Figure "E"*. Position the assembly so that the upper bracket is aligned vertically against the outside surface of the frame rail.

On some vehicles there may be a rivet head on the bottom of the bottom surface of the frame rail that will prevent the upper bracket from being mounted flush against the frame. To assure that the upper bracket clears the rivet head, install four large flat washers between the upper bracket and the bottom surface of the frame rail *see Figure "A"*. Installation of the flat washers is only necessary if your vehicle has a rivet head on the bottom of the frame rail. Insert a 1/4" -20 x 1" bolt through the vertical tab of the upper bracket and an existing hole in the frame rail. Secure with washers and a nut *see Figure "A"*. On some models, a hole must be drilled in the frame rail for the bolt to pass through. Using the upper bracket as a template, drill a 5/16" hole through the frame rail. Make sure that all electrical, brake, and fuel lines are cleared from the path of the drill.

The tabs on the bracket will be secured to the lower frame flange using 3/8" flanged lock nuts and 3/8" -16 x 1" hex bolts *see Figure "A"*. *Note: on the driver's side of the vehicle the 1/4" bolt will also hold a clip (on some models) used to hold brake and fuel lines. Secure the clip to the 1/4" bolt to secure the lines.*

Align the lower bracket against the U-bolts over the leaf spring stack *see Figure "E"*. After the bracket has been squared with the U-bolts, tighten the 3/8" hex bolt to secure the lower bracket to the air spring. Next, insert two 3/8" -16 x 3" carriage bolts into the square holes on the lower bracket. Install one axle strap on the bottom of the axle housing *see Figure "A"*. Slide the axle strap

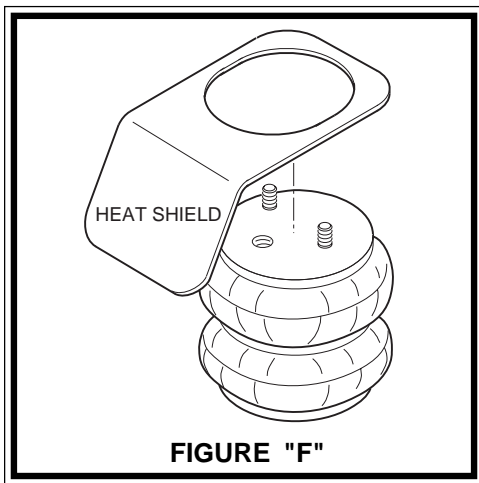

**FIGURE "F"**

on to the carriage bolts and secure with 3/8" - 16 flanged lock nuts. This installation will hold the lower bracket in place. *Note: When installing the left-side assembly, it will be necessary to tie the parking brake line to the sway bar to prevent it from contacting the air spring in normal operation. There must be at least 1/2" of clearance between the inflated air spring and any other part of the vehicle.*

#### **STEP 4 - INSTALL THE PASSENGER'S SIDE ASSEMBLY**

Follow steps 1 - 4 for assembly and installation of the passenger's side assembly. On the passenger's side it will be necessary to install a heat shield between the upper bracket and the air spring to protect the air spring from the exhaust pipe heat *see Figure "F"*. Position the heat shield so that it will reflect radiant heat from the point on the exhaust pipe closest to the air spring. The heat shield should be positioned so that it does not contact the axle housing as the suspension compresses.

#### **STEP 5 - INSTALL THE AIR LINE AND THE INFLATION VALVE**

Uncoil the air line tubing and cut it into two equal lengths. *DO NOT FOLD OR KINK THE TUBING.* Try to make the cut as square as possible. Insert one end of the tubing into the air fitting installed in the top of the air helper spring. Push the tubing into the fitting as far as possible.

Select a location on the vehicle for the air inflation valves. The location can be on the bumper or the body of the vehicle, as long as it is in a protected location so the valve will not be damaged, but maintain accessibility for the air chuck *see Figure "G"*. Drill a 5/16" hole and install the air inflation valve using two 5/16" flat washers per valve as supports *see Figure "H"*. Run the tubing from the air helper spring to the inflation valve, routing it to avoid direct heat from the exhaust pipe and away from sharp edges. Thermal sleeves have been provided for these conditions. If a thermal sleeve is required simply slide the sleeve over the air line tubing to the location requiring protection. The air line tubing should not be bent or curved sharply as it may buckle. Secure the tubing in place with the nylon ties provided. Push the end of the air line tubing into the inflation valve as illustrated *see Figure "H"*.

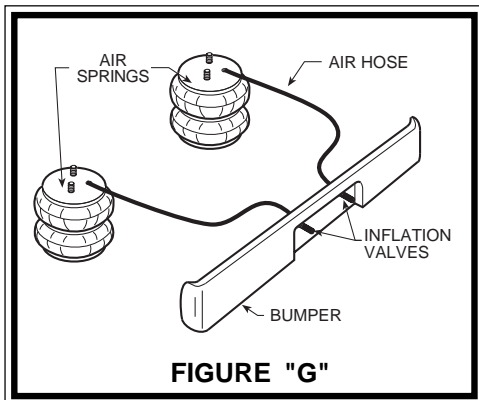

**FIGURE "G"**

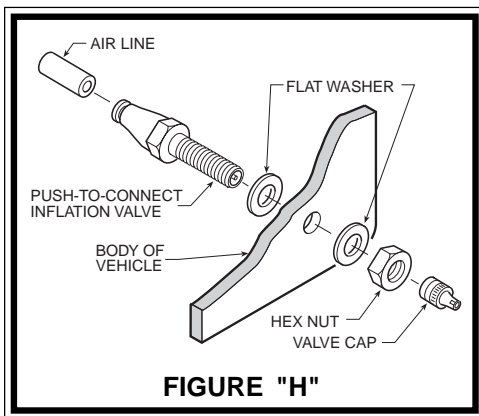

**FIGURE "H"**

#### **STEP 6 - CHECK THE AIR SYSTEM**

Once the inflation valves are installed inflate the air helper springs to 70 P.S.I. and check the fittings for air leaks with an applied solution of soap and water. If a leak is detected at a tubing connection, check to make sure that the tube is cut as square as possible and that it is pushed completely into the fitting. The tubing can easily be removed from the fitting by first releasing the pressure from the air spring, then by pushing the collar towards the body of the fitting and then pulling out the tube. If a leak is detected where the air fitting screws into the spring, release the air pressure, then remove the tubing as described above, then screw the brass fitting into the air spring one additional turn or until the leak stops. Reinstall the

tubing and reinflate the air springs and check for leaks as noted above.

This now completes the installation. Install the wheels and torque the lug nuts to the manufactures specifications. Raise the vehicle by the rear axle and remove the jack stands and lower the vehicle back onto the ground. Re-attach the positive battery cable and remove the wheel chocks from the wheels. Before proceeding, check once again to be sure you have proper clearance around the air springs. With a load on your vehicle and the air helper springs inflated, you must have at least 1/2" clearance around the air springs. As a general rule, the air helper springs will support approximately 50 lbs. of load for each P.S.I. of inflation pressure (per pair). For example, 50 P.S.I. of inflation pressure will support a load of 2500 lbs. per pair of air helper springs. *FORBESTRIDE* use only enough air pressure in the air helper springs to level the vehicle when viewed from the side (front to rear). This amount will vary depending on the load, location of load, condition of existing suspension and personal preference.

#### **NOTE:**

Too much air pressure in the air helper springs will result in a firmer ride, while too little air pressure will allow the air helper spring to bottom out over rough conditions. Too little air pressure will also not provide the possible improvement in handling. *TO PREVENT POSSIBLE DAMAGE MAINTAIN A MINIMUM OF 5 P.S.I. IN THE AIR HELPER SPRINGS AT ALL TIMES.*

#### **NOTE:**

Once the air helper springs are installed, it is recommended that the vehicle not be lifted by the frame, as over-extension may occur, resulting in damage to the air helper springs. However, should it become necessary to raise the vehicle by the frame, deflate both air helper springs completely.