



Unit 626 Kilshane Avenue, North West Business Park, Ballycoolin, Dublin 15, Ireland
 Telephone: +353 1 8612 632, Fax: +353 1 8612 647, email: sales@driveriteltd.com

W21-760-2071

INSTALLATION INSTRUCTIONS

All work should be carried out in a properly equipped workshop with due regard to Health and Safety Regulations. No further reference to Health and Safety Regulations will be made, but they must be considered at all times.

The kit should be opened and the contents checked against the parts list provided.

Identify the various components and familiarise yourself with them using drawings and information provided.

WARNING

Do not inflate this assembly when it is unrestricted. When installed, a minimum of 10 psi should be maintained in the air bellows at all times to avoid damage. Do not inflate beyond 100 psi.

IMPORTANT

This kit is not designed to increase the GVW of your vehicle. For your safety and to prevent possible damage to your vehicle, do not exceed the maximum load recommended by the vehicle manufacturer.

267G AIR SPRING	6781	2	3/8"-16 x 7" CARRIAGE BOLTS	8
UPPER BRACKETS	5376	2	3/8" FLAT WASHER	12
LOWER BRACKETS	5092	2	3/8"-16 X 1 1/2 HEX BOLTS	8
BRACKET STRAP/SHIM 1/2"	5086	4	5/16" FLAT WASHER	4
BRACKET STRAP/SHIM 1"	5093	4	PUSH TO CONNECT	
BRAKE LINE BRACKET	5427	1	INFLATION VALVE	2
AIR LINE TUBING		1	PUSH TO CONNECT	
3/8"-16 FLANGE LOCK NUT		21	ELBOW FITTING	2
3/8"-16 X 1" HEX BOLT		1	THERMAL SLEEVE	2
3/8"-16 X 3/4" FLANGE HEX BOLT		2	NYLON TIE	6

TOOLS REQUIRED

- (2) 9/16" END WRENCHES
- (2) 1/2" END WRENCHES
- UTILITY KNIFE
- ELECTRIC DRILL
- 5/16" DRILL BIT
- 3/8" DRILL BIT

FIGURE "A"

NOTE: Both illustrations are of the left, or drivers side, of the vehicle. Reverse any orientations when assembling and installing the right, or passenger, side of the vehicle.

**KIT TO FRAME ASSEMBLY
FITS WITH OR WITHOUT
OVERLOAD SPRINGS**

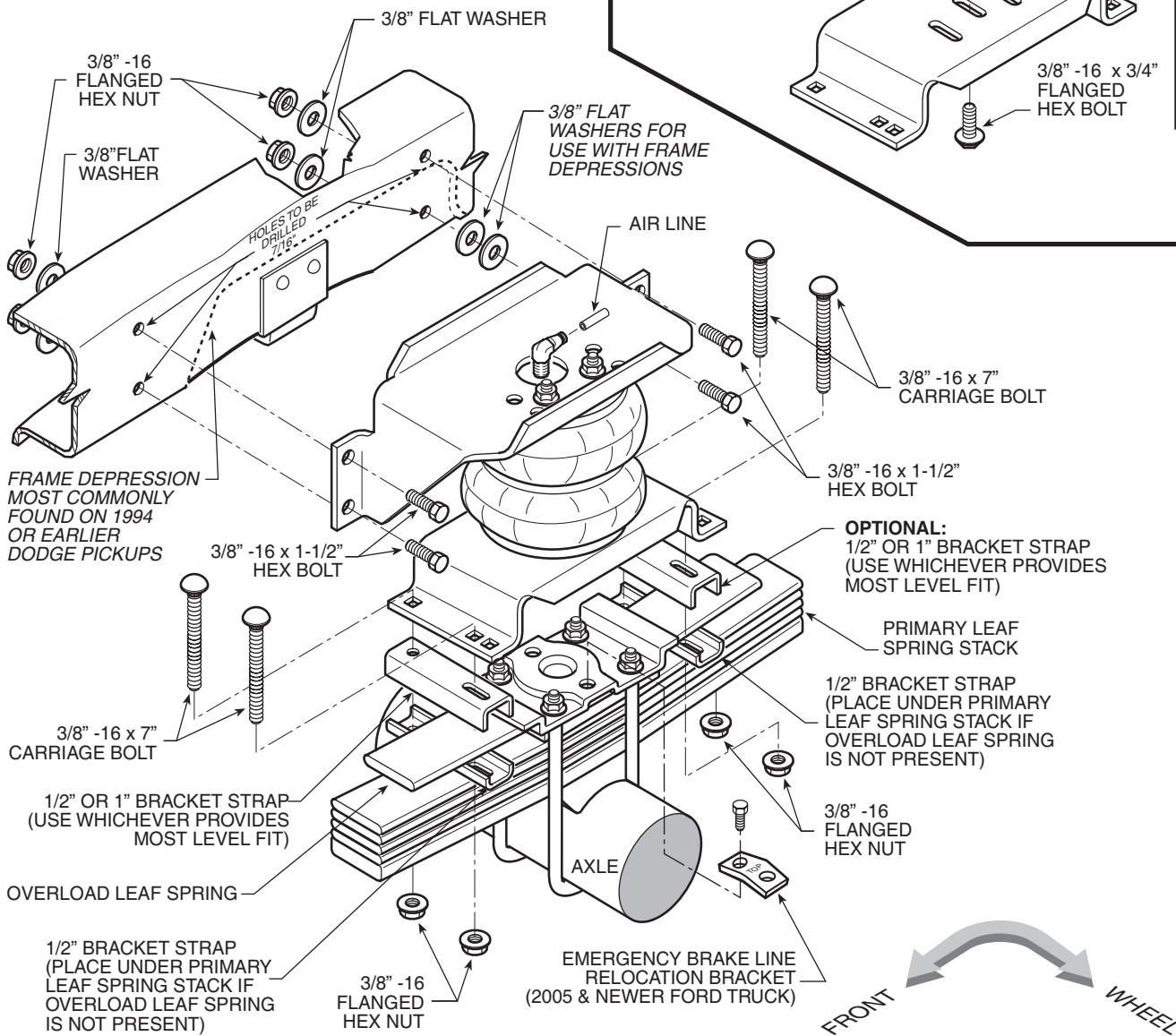

NOTICE FOR 1973-1987 2WD CHEVROLET AND GMC PICKUPS: THE LOWER BRACKET NEEDS TO BE REVERSED SO THAT THE LIP ON THE SIDE OF THE BRACKET IS FACING TOWARD THE CENTER OF THE VEHICLE. THE ROTATION OF THE LOWER BRACKET IS TO ENSURE PROPER AIR SPRING ALIGNMENT. THIS APPLICATION ALSO IS USED ON SOME FORD AND DODGE PICKUPS.

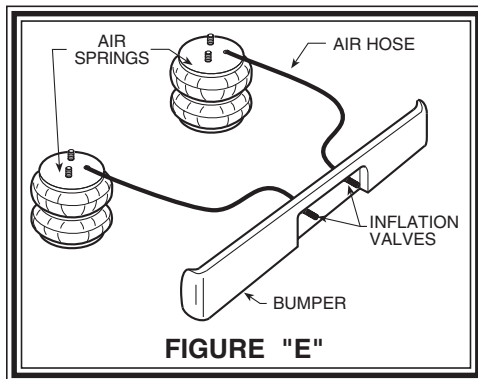
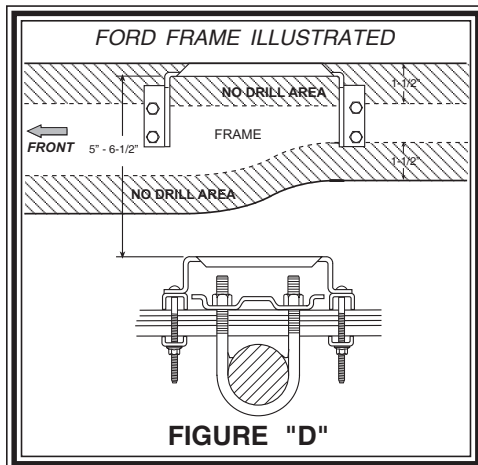
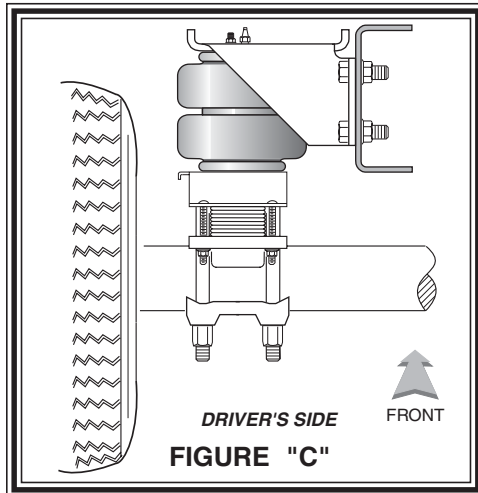
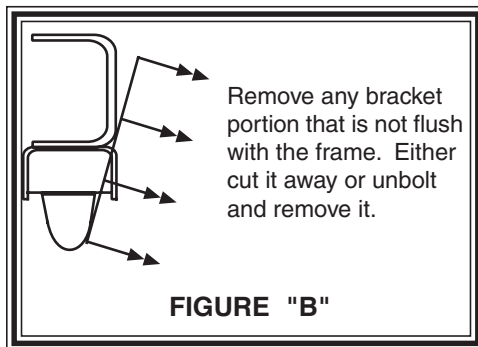

STEP 1 - PREPARE THE VEHICLE

With the vehicle on a solid, level surface chock the front wheels. Raise the vehicle by the rear axle and remove the rear wheels. After the removal of the wheels lower the vehicle so the axle rests on jack stands rated for your vehicles weight. Remove any jounce bumper bracket that is not mounted flush with the frame which will interfere with the operation of the air helper springs *see Figure "B"*. Jounce bumpers located under the frame rail may be left in place. ***This installation assumes that there is no load in the bed of the truck.*** Remove the negative battery cable.

On 2005 and newer Ford vehicles the emergency brake line bracket must be relocated. Remove the screw holding the brake line. Install the relocating bracket with the screw previously removed. ***NOTE: the bracket is marked top.*** Next, fasten the emergency brake line bracket to the relocation bracket using the 3/8" X 1" bolt and a 3/8" nut.

STEP 2 - PREASSEMBLE THE KIT

Select one air helper spring and an upper bracket from your kit. Align the studs of the air spring with the mounting holes of the upper bracket and insert. Make sure the air inlet is visible through the large access hole in the upper bracket. Fasten the upper bracket to the air spring using the 3/8"-16 flanged lock nuts, *see Figure "A"*. Install the elbow fitting into the air spring through the large access hole in the upper bracket. Tighten the air fitting securely to engage the orange thread sealant. Position the fitting to point to the anticipated location of the air inflation valves, *see Figure "A" & "E"*. Select one lower bracket and place the bracket so the lip of the lower bracket will be next to the tire, *see Figure "A"*. If you are installing this kit on a 1987 or earlier GMC pickup or a 1994 or earlier Dodge pickup review notices on *Figure "A"*. Fasten the lower bracket using a 3/8"-16 x 3/4" flange hex bolt (*finger tight*) through the center slot into the threaded hole in the air spring.

STEP 3 - PRE-FIT AND MARK / DRILL HOLES

Position the air spring assembly on the leaf spring stack. The lower bracket should straddle the leaf spring retainer and the upper bracket mounting flanges should be flush against the frame. Depending on the application, the lower bracket may have to be raised (i.e. interference with "U"-bolts, leaf spring retainer, brake drum, etc...). This kit comes with two sets of bracket straps/shims. These are included to provide adequate clearance for the air spring and lower bracket, as well as, any other component on the vehicle. One set is 1/2" tall while the other set is 1" tall. To raise the air spring assembly to its maximum height, install the 1" shim between the lower bracket and the leaf spring stack, *see Figure "D"*. The remaining 1/2" strap/shim will be used to clamp the assembly to the leaf spring stack, *see Figure "D"*. The bracket straps/shims may be interchanged, or not used, to provide maximum clearance and proper air spring height. Furthermore, the shims can be mixed (i.e. use the 1/2" on one side and the 1" or none on the other) to adjust for leaf spring slant.

Once the height of the lower bracket has been established, adjust the position of the upper bracket so that the mounting flanges are flush with the side of the frame rail. To do this, slide the air spring over the lower bracket along its slotted connection. With the brackets now positioned properly and the air spring in proper alignment, tighten the 3/8"-16 x 3/4" hex bolt securing the lower bracket to the air spring. It may be necessary to slide the entire assembly fore or aft along the leaf spring in order to provide clear mounting. Before marking and drilling the holes for the upper bracket, make sure the mounted height of the air spring is between 5.00" - 6-1/2", that there is at least 1-1/2" between the edge of the hole

and the inside of the upper and lower frame flange, and the upper and lower brackets are as parallel as possible, *see Figure "D"*. Mark the four holes to be drilled with a center punch using the upper bracket as a template, then remove the air spring assembly. ***Before drilling the holes make sure all electrical, brake and fuel lines are cleared from the path of the drill.*** Damage to lines can be avoided by inserting a piece of wood between the frame rail and any lines in the path of the drill. Drill the four holes in the frame rail using a 3/8" drill bit, *see Figure "A"*.

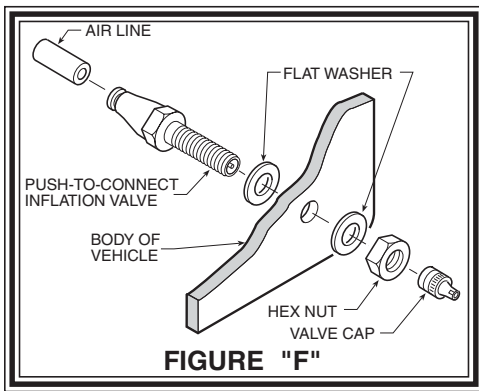

STEP 4 - INSTALLATION TO THE VEHICLE

After drilling the holes in the frame rail place the assembled air spring back on the leaf stack making sure the lower bracket is placed over the retainer, *see Figure "A" & "C"*. Check to see Ford trucks that there is a 1/2" of clearance between the air spring and the emergency brake line bolt, this bolt may have to be cut down for clearance. Install the 3/8"-16 x 1 1/2" hex bolts through the upper bracket holes and the holes that were drilled in the frame rail. Next fasten the upper bracket to the frame rail using the 3/8"-16 flange lock nuts and flat washers to the back side of the frame rail, refer to *Figure "A"*. The next step is to attach the lower bracket to the leaf spring assembly. Use the bracket strap/shim that is not being used as a spacer or 1/2" spacer/shim if no spacer is required, and fasten the air spring assembly to the leaf stack using the 3/8"-16 x 7" carriage bolts and 3/8"-16 flanged lock nuts, *see*

Figure "A". **NOTE:** You may clamp around the over-load leaves. Insert the carriage bolt through the inner square hole on the lower bracket for narrow leaf springs.

STEP 5 - INSTALLATION TO THE PASSENGER'S SIDE ASSEMBLY

Reverse any orientations when assembling and installing the right, or passenger, side of the vehicle.

STEP 6 - INSTALL THE AIR LINE AND THE INFLATION VALVE

Uncoil the air line tubing and cut it into two equal lengths. **DO NOT FOLD OR KINK THE TUBING.** Try to make the cut as square as possible. Insert one end of the tubing into the elbow fitting installed in the top of the air helper spring. Push the tubing into the fitting as far as possible, *see Figure "A"*.

Select a location on the vehicle for the air inflation valves. The location can be on the bumper or the body of the vehicle, as long as it is in a protected location so the valve will not be damaged, but maintain accessibility for the air chuck, *see Figure "E"*. Drill a 5/16" hole and install the air inflation valve using two 5/16" flat washers per valve as supports, *see Figure "F"*. Run the tubing from the air helper spring to the inflation valve, routing it to avoid direct heat from the engine, exhaust pipe, and away from sharp edges. Thermal sleeves have been provided for these conditions. If a thermal sleeve is required simply slide the sleeve over the air line tubing to the location requiring protection. The air line tubing should not be bent or curved sharply as it may buckle. Secure the tubing in place with the nylon ties provided. Push the end of the air line tubing into the inflation valve as illustrated, *see Figure "F"*.

STEP 7 - CHECK THE AIR SYSTEM

Once the inflation valves are installed inflate the air helper springs to 70 *psi* and check the fittings for air leaks with an applied solution of soap and water. If a leak is detected at a tubing connection then check to make sure that the tube is cut as square as possible and that it is pushed completely into the fitting. The tubing can easily be removed from the fittings by pushing the collar towards the body of the fitting and then pulling out the tube. If a leak is detected where the brass fitting screws into the spring, remove the tubing by pushing the collar towards the body of the fitting and then pulling out the tube, then screw the brass fitting into the air spring one additional turn or until the leak stops. Reinstall the tubing and reinflate the air springs and check for leaks as noted above.

This now completes the installation. Install the wheels and torque the lug nuts to the manufactures specifications. Raise the vehicle by the rear axle and remove the jack stands and lower the vehicle back onto the ground. Re-attach the negative battery cable and remove the wheel chocks from the wheels. Before proceeding, check once again to be sure you have proper clearance around the air springs. With a load on your vehicle and the air helper springs inflated, you must have at least 1/2" clearance around the air springs. As a general rule, the air helper springs will support approximately 40 lbs. of load for each *psi* of inflation pressure (per pair). For example, 50 *psi* of inflation pressure will support a load of 2000 lbs. per pair of air helper springs. **FOR BEST RIDE** use only enough air pressure in the air helper springs to level the vehicle when viewed from the side (front to rear). This amount will vary depending on the load, location of load, condition of existing suspension and personal preference.

NOTE:

Too much air pressure in the air helper springs will result in a firmer ride, while too little air pressure will allow the air helper spring to bottom out over rough conditions. Too little air pressure will also not provide the improvement in handling that is possible. **TO PREVENT POSSIBLE DAMAGE MAINTAIN A MINIMUM OF 5 *psi* IN THE AIR HELPER SPRINGS AT ALL TIMES.**

Once the air helper springs are installed, it is recommended that the vehicle not be lifted by the frame, as over-extension may occur, resulting in damage to the air helper springs. However, should it become necessary to raise the vehicle by the frame, deflate both air helper springs completely.