



Unit 626 Kilshane Avenue, North West Business Park, Ballycoolin, Dublin 15, Ireland  
 Telephone: +353 1 8612 632, Fax: +353 1 8612 647, email: sales@driveriteltd.com

## W21-760-0830

### INSTALLATION INSTRUCTIONS

All work should be carried out in a properly equipped workshop with due regard to Health and Safety Regulations. No further reference to Health and Safety Regulations will be made, but they must be considered at all times.

The kit should be opened and the contents checked against the parts list provided.

Identify the various components and familiarise yourself with them using drawings and information provided.

#### **WARNING**

*Do not inflate this assembly when it is unrestricted. When installed, a minimum of 10 psi should be maintained in the air bellows at all times to avoid damage. Do not inflate beyond 100 psi.*

#### **IMPORTANT**

*This kit is not designed to increase the GVW of your vehicle. For your safety and to prevent possible damage to your vehicle, do not exceed the maximum load recommended by the vehicle manufacturer.*

#### Parts List

224C AIR SPRING	6859	2	3/8" -16 x 3/4" HEX BOLT	6
UPPER BRACKET	0828	2	3/8" -24 x 2-1/2"	
UPPER BRACE (1A)	0861	2	RIBBED NECK BOLT 8084	10
UPPER BRACE (1B)	0821	2	3/8" -16 HEX NUT	4
SLEEVE	0823	4	3/8" -24 HEX NUT	10
SLEEVE EXTENSION	0941	4	3/8" LOCK WASHER	14
LOWER BRACKET	1162	2	3/8" FLAT WASHER	2
BRACKET STRAP	1163	4	1/4" x 20 x 4-1/2" HEX BOLT	4
AIR LINE TUBING		1	1/4" -20 HEX NUT	4
PUSH-TO-CONNECT			1/4" LOCK WASHER	4
INFLATION VALVE		2	1/4" FLAT WASHER	8
PUSH-TO-CONNECT			5/16" FLAT WASHER	4
ELBOW FITTING		2	NYLON TIE	6
HEAT SHIELD		1		

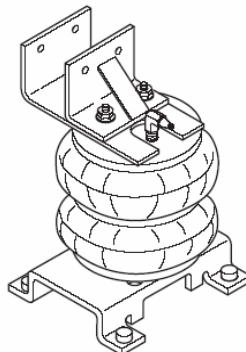

0830

FIGURE "A"

KIT TO FRAME ASSEMBLY

**NOTE:** Both illustrations are of the left, or driver's side, of the vehicle. Reverse any orientations when installing the right, or passenger's side assembly.

**KIT ASSEMBLY**

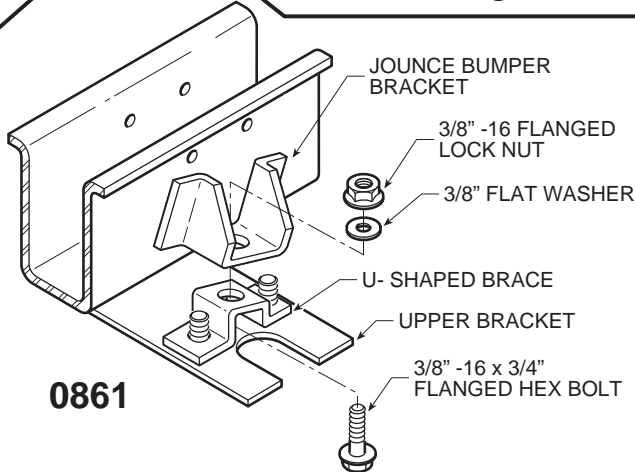
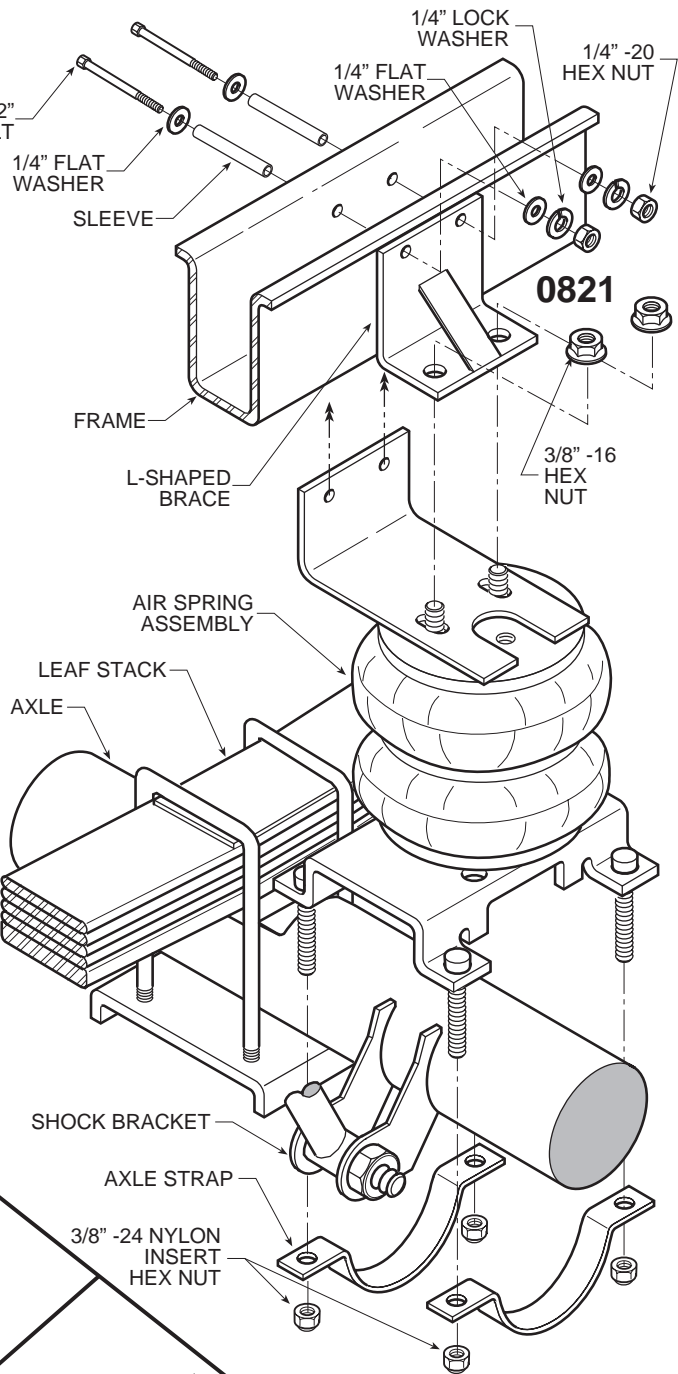
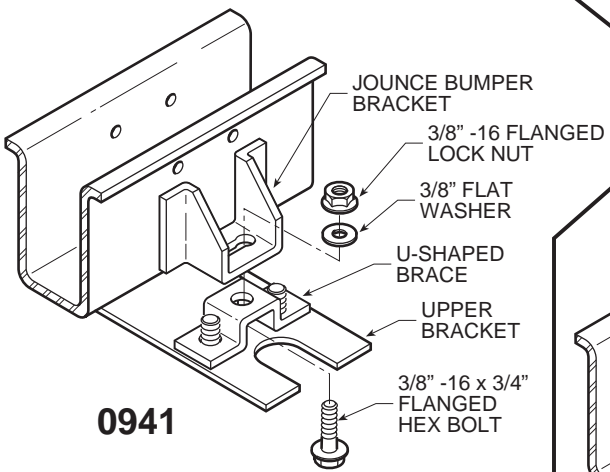
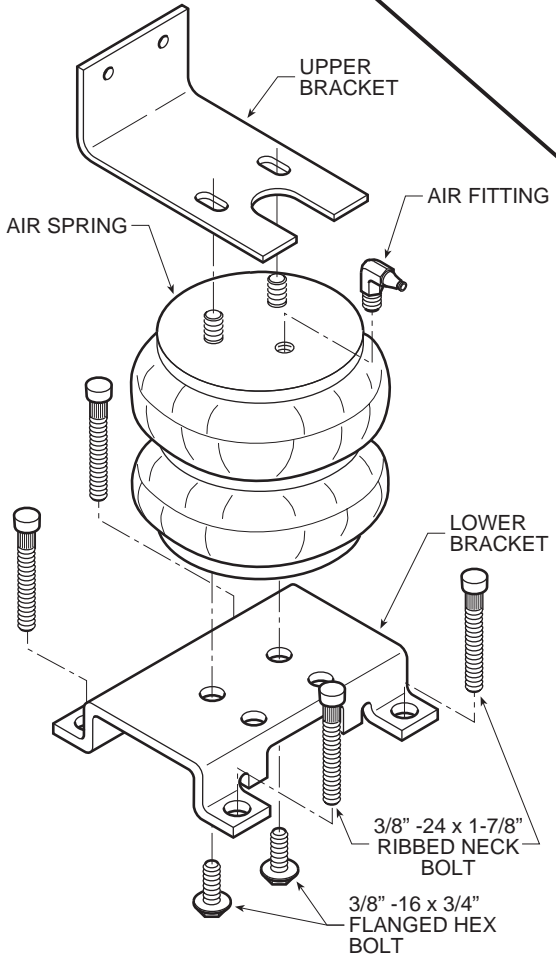

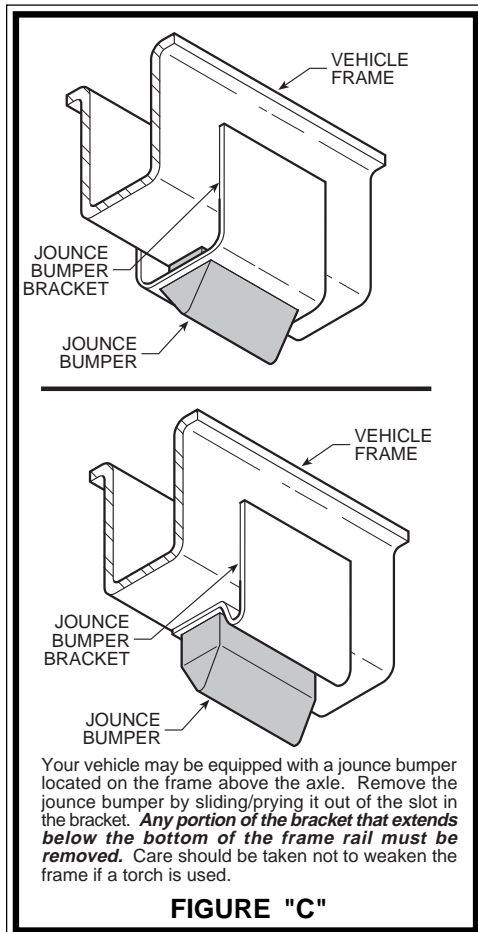
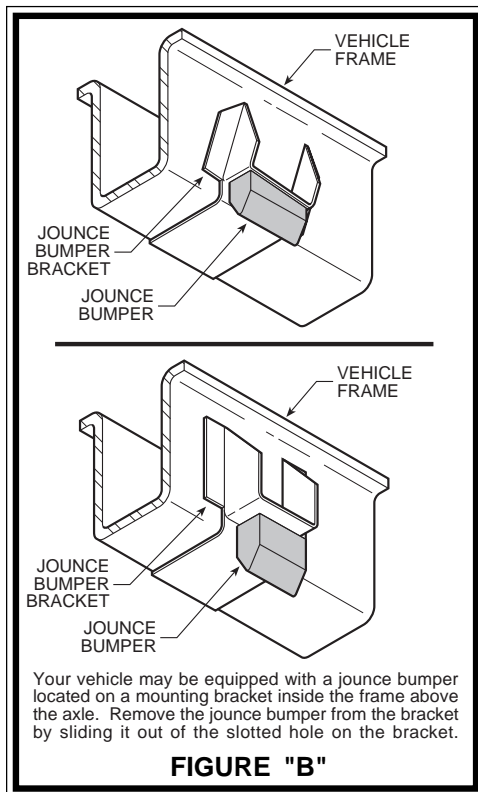

## STEP 2 - PRE-ASSEMBLE THE KIT

Install the push-to-connect elbow fitting in the top of the air spring. Tighten the fitting securely to engage the orange thread sealant. Position the fitting so that it points toward the inside of the vehicle *see Figures "A" & "E"*. The elbow should be installed so that it does not point toward the exhaust pipe. Align the threaded studs on the air spring with the slots in the upper bracket. Insert the threaded studs into the slots in the bracket and install the brace that corresponds to your vehicle *see Figure "A"*. If your vehicle requires either U-shaped brace, install 3/8" -16 x 3/4" flanged hex bolt in the brace before attaching it to the upper bracket *see Figure "A"*. Secure the upper bracket and brace to the air spring with two 3/8" -16 hex nuts (*finger tight*).

Select a lower bracket from your kit. Install four 3/8" -24 x 2-1/2" ribbed neck bolts in the four holes in the lower bracket and seat them in the bracket with a hammer *see Figure "A"*. Attach the lower bracket to the air spring with two 3/8" -16 x 3/4" flanged hex bolts. Either set of holes in the lower bracket may be used to attach the bracket to the air spring. Use the set of holes that allows the assembly to set on the axle housing without interfering with the vehicle's shock bracket.

## STEP 3 - INSTALL THE ASSEMBLY TO THE VEHICLE

Set the air spring assembly on top of the axle housing so that the lower bracket straddles the vehicle's shock bracket *see Figure "D"*. Position the assembly so that the upper bracket is flush against the side of the frame rail. If your vehicle requires the L-shaped brace, the brace should be flush against the inside of the frame rail. Ensure that the air spring is aligned vertically *see Figures "A" & "D"*.

Using the holes in the upper bracket as a template, drill two 3/8" holes completely through the frame rail. *Before drilling the holes, make sure all electrical, brake, and fuel lines are cleared from the path of the drill.* In order to prevent any damage to these lines, it is recommended that a thin piece of wood be placed between the frame rail and the existing lines while drilling the frame. Secure the assembly to the frame using the provided 1/4" -20 x 4-1/2" hex bolts, 1/4" flat washers, 1/4" lock washers, 1/4" -20 hex nuts, and steel sleeves *see Figure "A"*. *Do not over-tighten.*

**NOTE:** If your vehicle requires the L-shaped brace, the hex bolts will pass through the upper bracket, frame rail, and brace. If your vehicle requires either U-shaped brace, the hex bolts will only pass through the upper bracket and frame rail *see Figure "A"*. On vehicles requiring the U-shaped brace, secure the brace to the jounce bumper bracket with the provided 3/8" -16 flanged lock nut, 3/8" flat washer, and the installed flanged hex bolt.

**NOTE:** On some vehicles, the long sleeve will not span the entire gap in the frame rail. In such cases, it may be necessary to use the short and long sleeves together to span the gap in the frame rail. Do not use the sleeves if they prevent the bolt from being tightened securely on the frame. The sleeves are used to prevent the bolts from being over-tightened and crushing the vehicle's frame.

**NOTE:** The holes in the axle straps are not centered on the strap. The orientation of the axle straps can be changed so that they clear the vehicle's shock bracket on the axle housing.

Secure the lower bracket to the axle housing by installing two axle straps underneath the axle. Secure the axle straps to the ribbed neck bolts with the 3/8" -24 nylon insert lock nuts. Tighten the 3/8" -16 hex nuts, securing the air spring and brace to the upper bracket.

Re-install the wheel and torque the lug nuts to factory specifications. Raise the vehicle by the frame and remove the jack stands.

## STEP 4 - INSTALL THE AIR LINE AND THE INFLATION VALVE

Uncoil the air line tubing and cut it into two equal lengths. **DO NOT FOLD OR KINK THE TUBING.** Try to make the cut as square as possible. Insert one end of the tubing into the air fitting installed in the top of the air spring. Push the tubing into the fitting as far as possible.

Select a location on the vehicle for the air inflation valves. The location can be on the bumper or the body of the vehicle, as long as it is in a protected location so the valve will not be damaged, but maintain accessibility for the air chuck *see Figure "E"*.

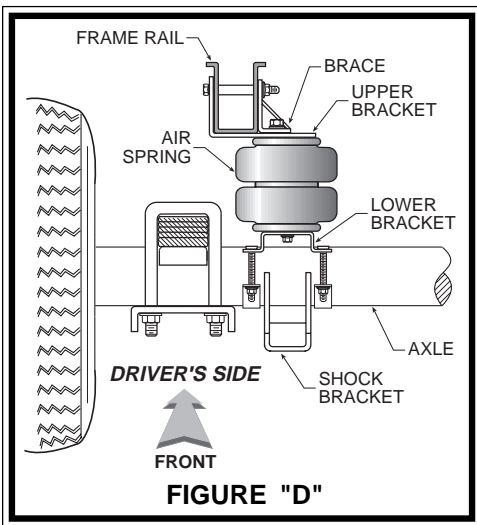

**FIGURE "D"**

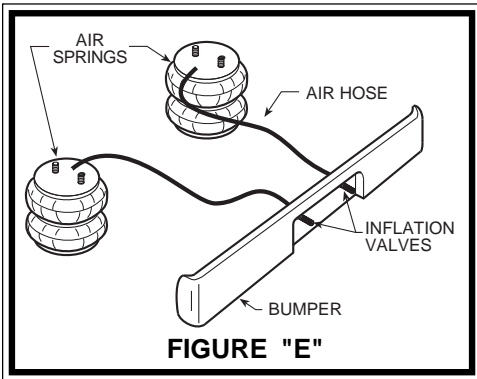

**FIGURE "E"**

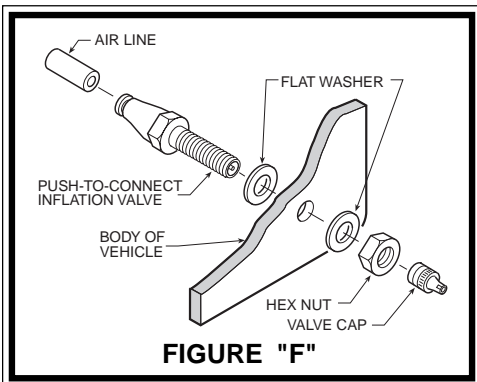

**FIGURE "F"**

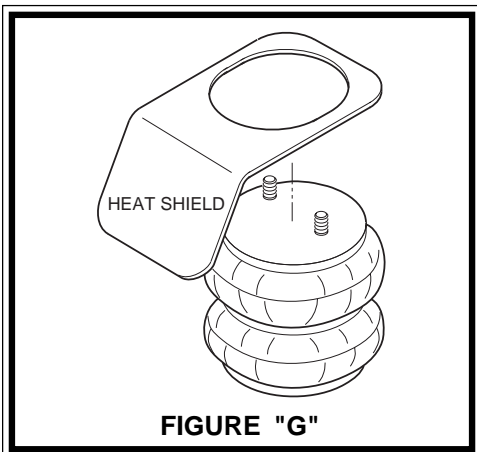

**FIGURE "G"**

Drill a 5/16" hole and install the air inflation valve using two 5/16" flat washers per valve as supports *see Figure "F"*. Run the tubing from the air spring to the inflation valve, routing it to avoid direct heat from the exhaust pipe and away from sharp edges. Thermal sleeves have been provided for these conditions. If a thermal sleeve is required, slide the sleeve over the air line tubing to the location requiring protection. The air line tubing should not be bent or curved sharply as it may buckle. Secure the tubing in place with the nylon ties provided. Push the end of the air line tubing into the inflation valve as illustrated *see Figure "F"*.

### **STEP 5 - INSTALL THE PASSENGER'S SIDE ASSEMBLY**

Follow steps 1-4 for assembly and installation of the passenger's side assembly. *Note: The use of a heat shield is required on the passenger's side of the vehicle.* The heat shield will mount between the upper bracket and the air helper spring *see Figure "G"*. Position the shield between the nearest point of the exhaust pipe to the rubber air spring. Ensure that the heat shield will not interfere with the normal operation of the air spring or the vehicle's suspension. Do not position the face of the shield directly over the axle, as it may contact the axle on full suspension compression.

### **STEP 6 - CHECK THE AIR SYSTEM**

Once the inflation valves are installed inflate the air helper springs to 70 psi. and check the fittings for air leaks with an applied solution of soap and water. If a leak is detected at a tubing connection, check to make sure that the tube is cut as square as possible and that it is pushed completely into the fitting. The tubing can easily be removed from the fitting by first releasing the pressure from the air spring, then by pushing the collar towards the body of the fitting and then pulling out the tube. If a leak is detected where the air fitting screws into the spring, release the air pressure, then remove the tubing as described above, then screw the brass fitting into the air spring one additional turn or until the leak stops. Reinstall the tubing and reinflate the air springs and check for leaks as noted above.

This now completes the installation. Re-attach the negative battery cable and remove the wheel chocks from the wheels. Before proceeding, check once again to be sure you have proper clearance around the air springs. With a load on your vehicle and the air helper springs inflated, you must have at least 1/2" clearance around the air springs. As a general rule, the air helper springs will support approximately 50 lbs. of load for each psi. of inflation pressure (per pair). For example, 50 psi. of inflation pressure will support a load of 2500 lbs. per pair of air helper springs. **FOR BEST RIDE** use only enough air pressure in the air helper springs to level the vehicle when viewed from the side (front to rear). This amount will vary depending on the load, location of load, condition of existing suspension and personal preference.

### **NOTE:**

Too much air pressure in the air helper springs will result in a firmer ride, while too little air pressure will allow the air helper spring to bottom out over rough conditions. Too little air pressure will also not provide the possible improvement in handling. **TO PREVENT POSSIBLE DAMAGE MAINTAIN A MINIMUM OF 5 psi. IN THE AIR HELPER SPRINGS AT ALL TIMES.**

### **NOTE:**

Once the air helper springs are installed, it is recommended that the vehicle not be lifted by the frame, as over-extension may occur, resulting in damage to the air helper springs. However, should it become necessary to raise the vehicle by the frame, deflate both air helper springs completely.